

OMATIC RIFLE

Y DESIGN MKE

G3 AUTOMATIC

C 7.62x51mm

al Industries Corporation

G3 AUTOMATIC



G3 AUTOMATIC RIFLE

7.62x51 mm

USER MANUAL

V.01



INDEX

G3 AUTOMATIC RIFLE	2
Technical Specifications	2
WARNINGS.....	3
Safety Rules.....	3
G3 AUTOMATIC RIFLE ASSEMBLY GROUPS	4
Receiver and Barrel Assembly.....	5
Bolt Carrier Assembly	5
Buttstock Assembly.....	6
Grip Assembly	6
Hand Guard.....	7
Magazine Assembly	7
G3 AUTOMATIC RIFLE DISASSEMBLY PROCEDURES	8
Magazine Removal	8
Buttstock Removal	8
Bolt Carrier Removal.....	9
Grip Removal	9
Hand Guard Removal.....	10
G3 AUTOMATIC RIFLE REASSEMBLY	10
G3 AUTOMATIC RIFLE OPERATION	11
Safe and Fire Selector Operation	11
Loading and Unloading the Magazine.....	12
Loading the Firearm.....	14
Unloading the Firearm.....	15
Firearm Operating System	15
Trigger Operating System	18
G3 AUTOMATIC RIFLE SIGHTS	25
Using the Sights	25
Rear Sight Adjustments	26
FIREARM MAINTENANCE.....	27
Disassembly and Maintenance of Bolt Carrier	28
Trigger Pack Removal and Maintenance.....	30
USING THE MULTI-PURPOSE CARRYING SLING	31
Putting the Carrying Sling in to the Firearm.....	31
How to Wear The Multi-Purpose Carrying Sling.....	32
Carrying and Slings Modes	32
Shooting Modes	33
TROUBLESHOOTING	34

G3 AUTOMATIC RIFLE

G3 Automatic Rifle, have been manufactured by MKE Corporation. The Rifle G3 is an automatic small arm which permits to fire single shots or short bursts from all firing positions. Are manufactured utilizing the latest production techniques and machinery. Utilize the reliable roller-lock, delayed blowback operating system. Are manufactured with cold hammer forged chrome moly vanadium barrels. Are chambered for the 7.62x51 mm cartridge.



Figure-1 G3 Automatic Rifle

Technical Specifications

Calibre	7.62x51 mm NATO
OA Length	1020 mm
Length of Barrel	450 mm
Sight Radius	572 mm
Number of Grooves	4
Weight of Weapon (without Magazine)	4,250 Kg
Rate of Fire	500-600 r.p.m
Muzzle Velocity	780-800 m/s
Normal Range for Use	400 m

WARNINGS

- Handle the rifle respectfully if optics are installed.
- Use the rifle after carefully reading through the user manual and understanding all the instructions. A mistake can cause the death of yourself or someone elses.
- Treat the rifle as if it is loaded
- Do not use the rifle if you're intoxicated or have been drinking or using drugs.
- Treat the rifle as if it is loaded.
- Do not use this rifle if you are not physically or mentally capable.

Safety Rules

- Read this manual carefully and make sure you are able to handle the rifle safely before you use it.
- Before using or cleaning the rifle, make sure;
 - The bolt is locked,
 - The chamber is empty,
 - The barrel is not blocked.
- The rifle should never be pointed at any person, only the target or game to be shot.
- When storing the rifle, don't store ammunition in the same case.
- Keep your finger off the trigger when loading, unloading and holding the rifle.
- Do not force any parts of the rifle when disassembling, cleaning and assembling.
- Use ear protection when firing.
- Make sure there are no obstructions in the barrel when firing.
- Use undamaged 7.62x51 mm cartridges.
- Do not use reloaded ammo. This will void warranty.



Always point the rifle at a safe direction.

G3 AUTOMATIC RIFLE ASSEMBLY GROUPS



Figure-2 G3 Automatic Rifle Assembly Groups

- 1. Receiver and Barrel Assembly
- 2. Bolt Carrier Assembly
- 3. Trigger Housing Assembly
- 4. Buttstock Assembly
- 5. Hand Guard
 - a. Standard Hand Guard

- b. Tropical Hand Guard
- 6. Magazine Assembly
 - a. Metal Magazine
 - b. Plastic Magazine
- 7. Take-down Pin
- 8. Take-down Pin

1. Receiver and Barrel Assembly

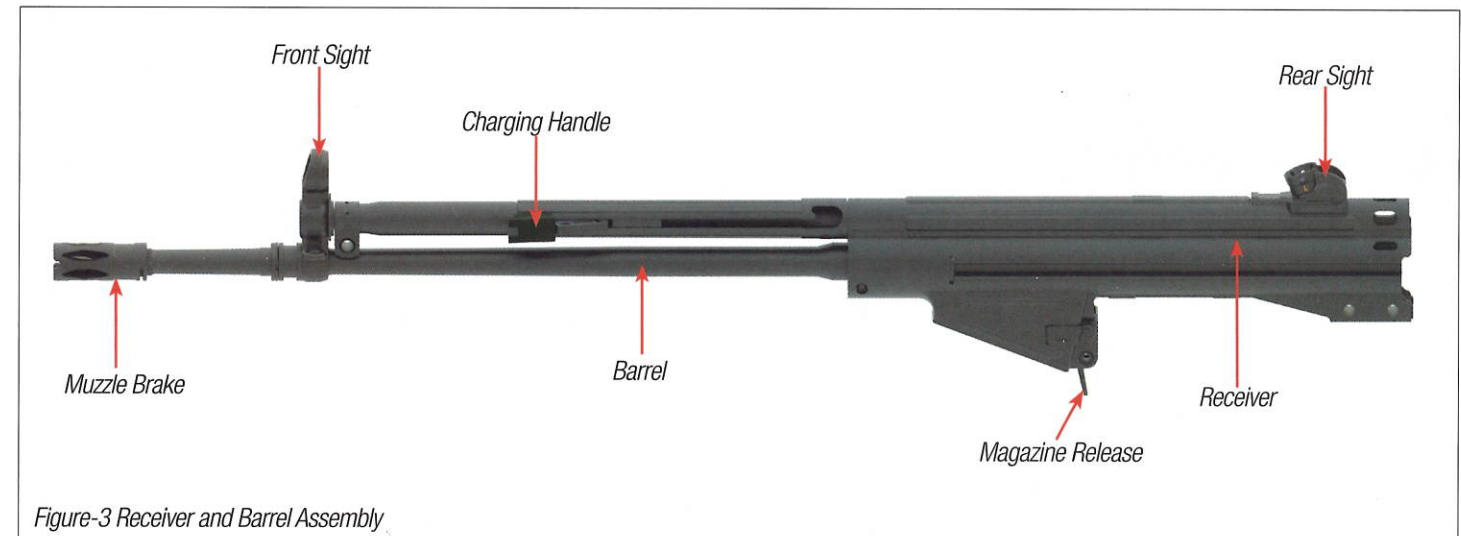

Figure-3 Receiver and Barrel Assembly

Barrel, charging (cocking) handle, Picatinny rail, and both sights are attached to the receiver. The muzzle brake is attached to the barrel end by way of a 15x1 RHM thread. It is held in place by a set screw with a 2 mm socket head screw.

The barrel is attached to the trunnion with a barrel retention pin (not removable). The charging handle is located above the barrel and is used to cycle the weapon and chamber a round and can be used to lock the bolt back to put the firearm in a safe condition.

The front sight is a fixed blade in a protected ring, and the rear sight is a protected drum, adjustable for windage and elevation. This drum has four apertures corresponding to 100, 200, 300, and 400 meters. The 100 meter is a V notch.

2. Bolt Carrier Assembly

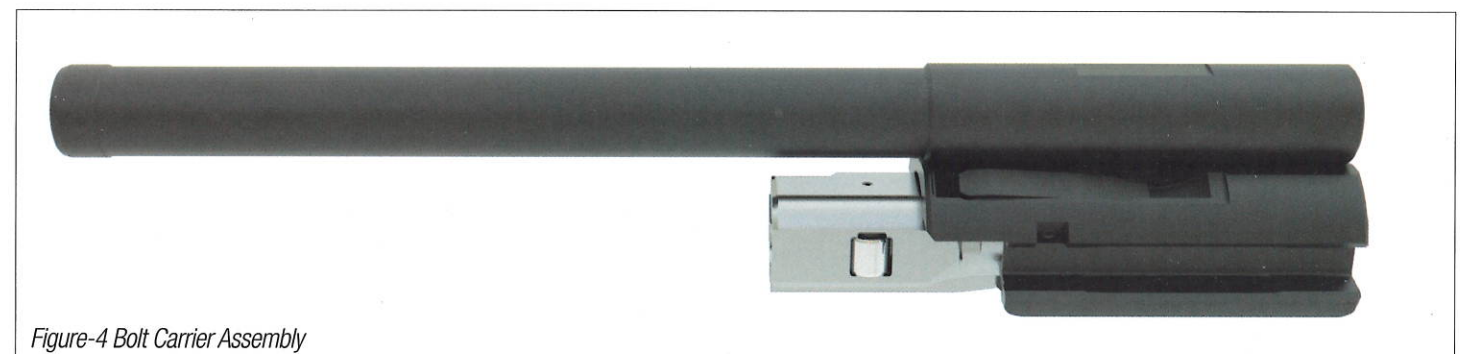

Figure-4 Bolt Carrier Assembly

The bolt locks the barrel at the moment of fire, it is guided in the receiver and feeds the cartridge, extracts and ejects the cartridge case, and cocks the hammer.

The bolt head carrier along with the recoil spring tube carries the bolt head. On both sides it has studs whereby it slides in the guiding grooves of the receiver.

Bolt Carrier Assembly Contains the Following Parts;

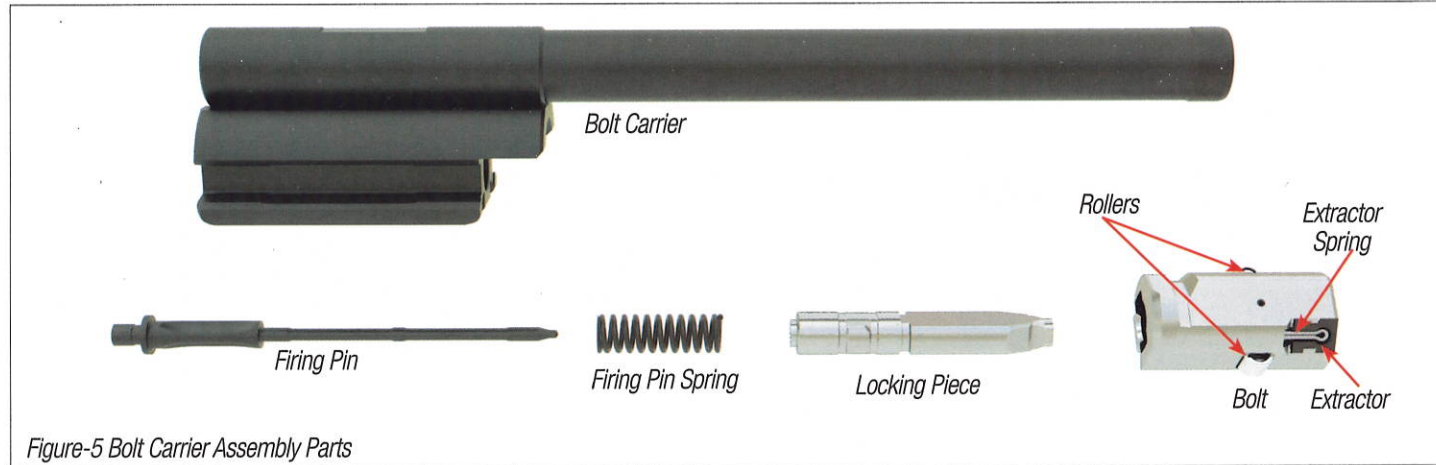

Figure-5 Bolt Carrier Assembly Parts

3. Buttstock Assembly

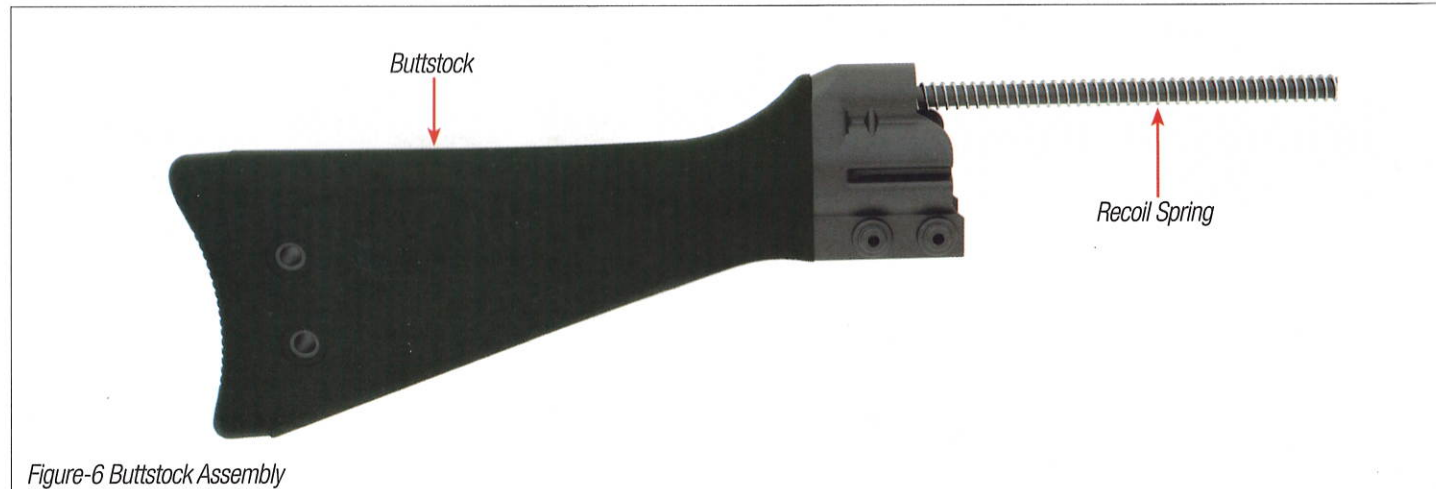

Figure-6 Buttstock Assembly

The butt stock permits an adequate handling of the weapon and its putting against the shoulder. The back plate with butt stock closes the rear of the receiver. It is fixed to the receiver by means of two locking pins. The recoil spring tube is riveted in the upper part of the back plate. On the left side of the butt stock the sling holder is trimmed in. When the weapon is stripped, the tubular rivets serve as place for the locking pins.

4. Grip Assembly



Figure-7 Grip Assembly

The grip assembly contains the trigger assembly housing and is connected to the receiver by means of the locking pin. The grip assembly receives all components of the trigger mechanism, hammer, ejector and safety mechanism.

5. Hand Guard

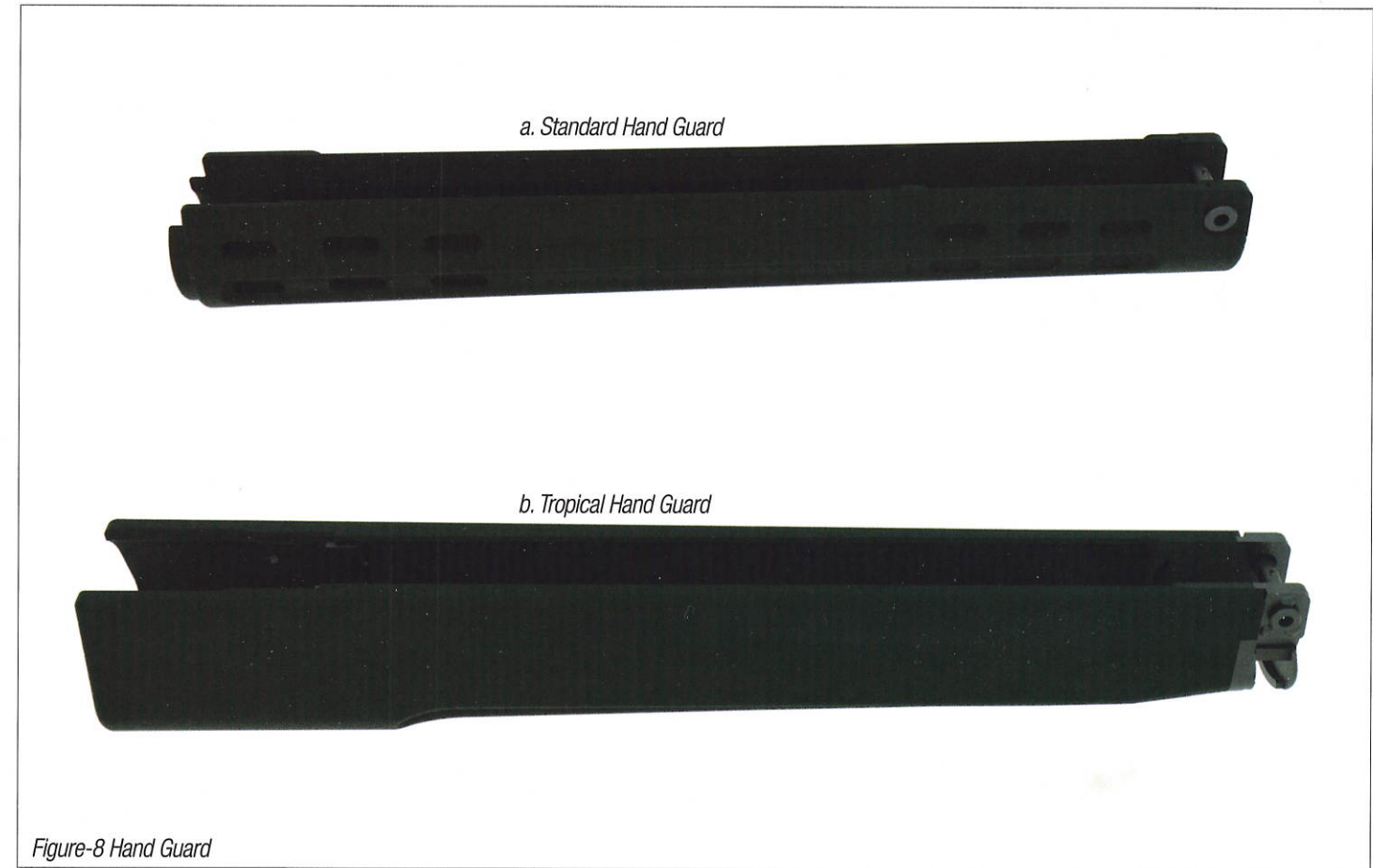

Figure-8 Hand Guard

The plastic handguard covers the barrel from below and facilitates the handling of the rifle when the barrel is hot. The lining riveted into the handguard serves as protection against heating of the handguard. The locking pin serves as fastening.

6. Magazine Assembly



Figure-9 Magazine Assembly

The magazine receives the cartridges and assures the cartridge feed. It is a straight box-type magazine and has a capacity of 20 cartridges.



G3 AUTOMATIC RIFLE DISASSEMBLY PROCEDURES

1. Magazine Removal



Figure-10 Magazine Removal

Press the magazine release button or paddle (see image a). Remove the magazine by pulling downward (see image b).

2. Buttstock Removal

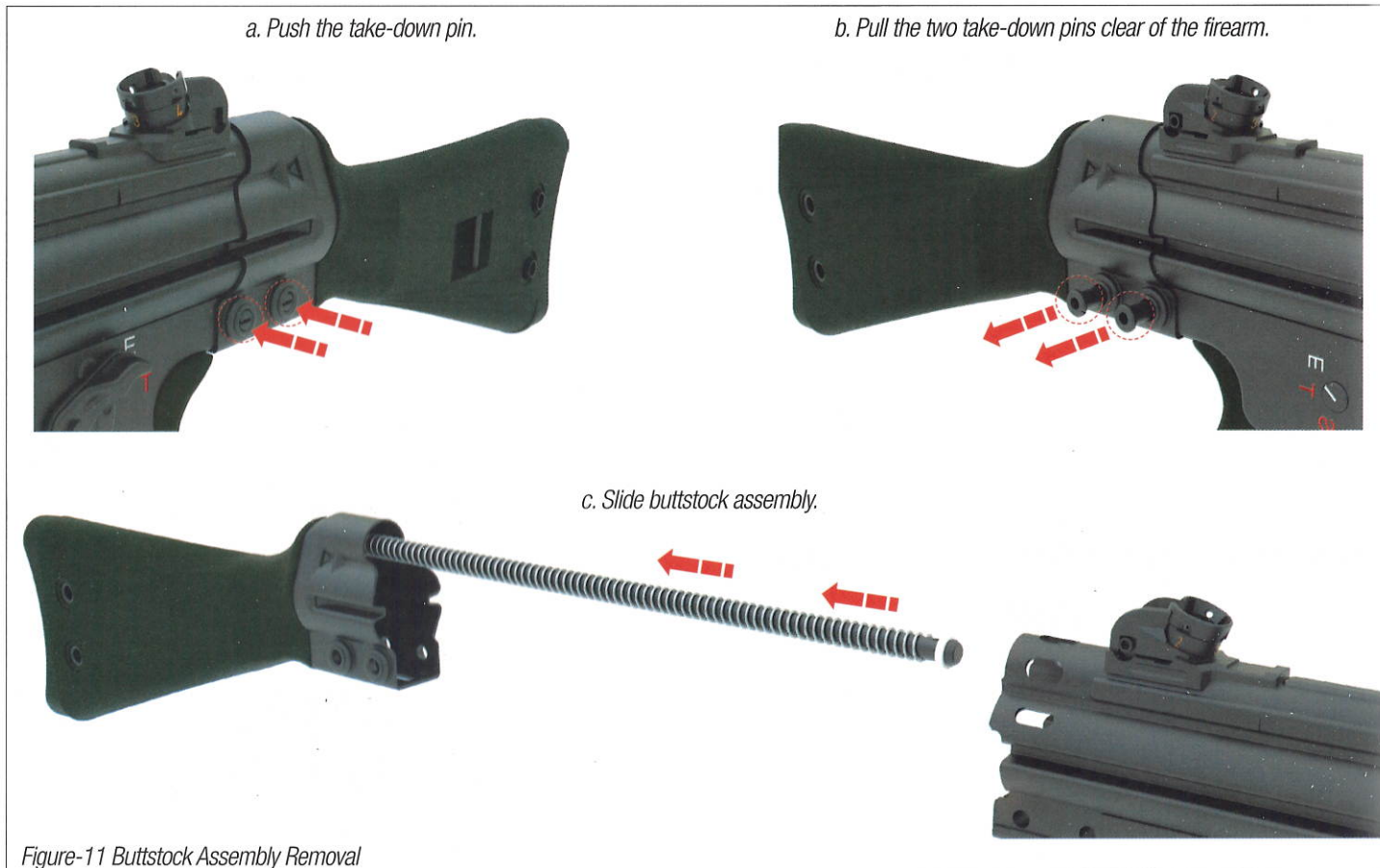

Figure-11 Buttstock Assembly Removal

Push the pin inward (see image a). On the other side of the firearm, Remove the take-down pin (see image b). Slide buttstock rearward until separated (see image c).



3. Bolt Carrier Removal

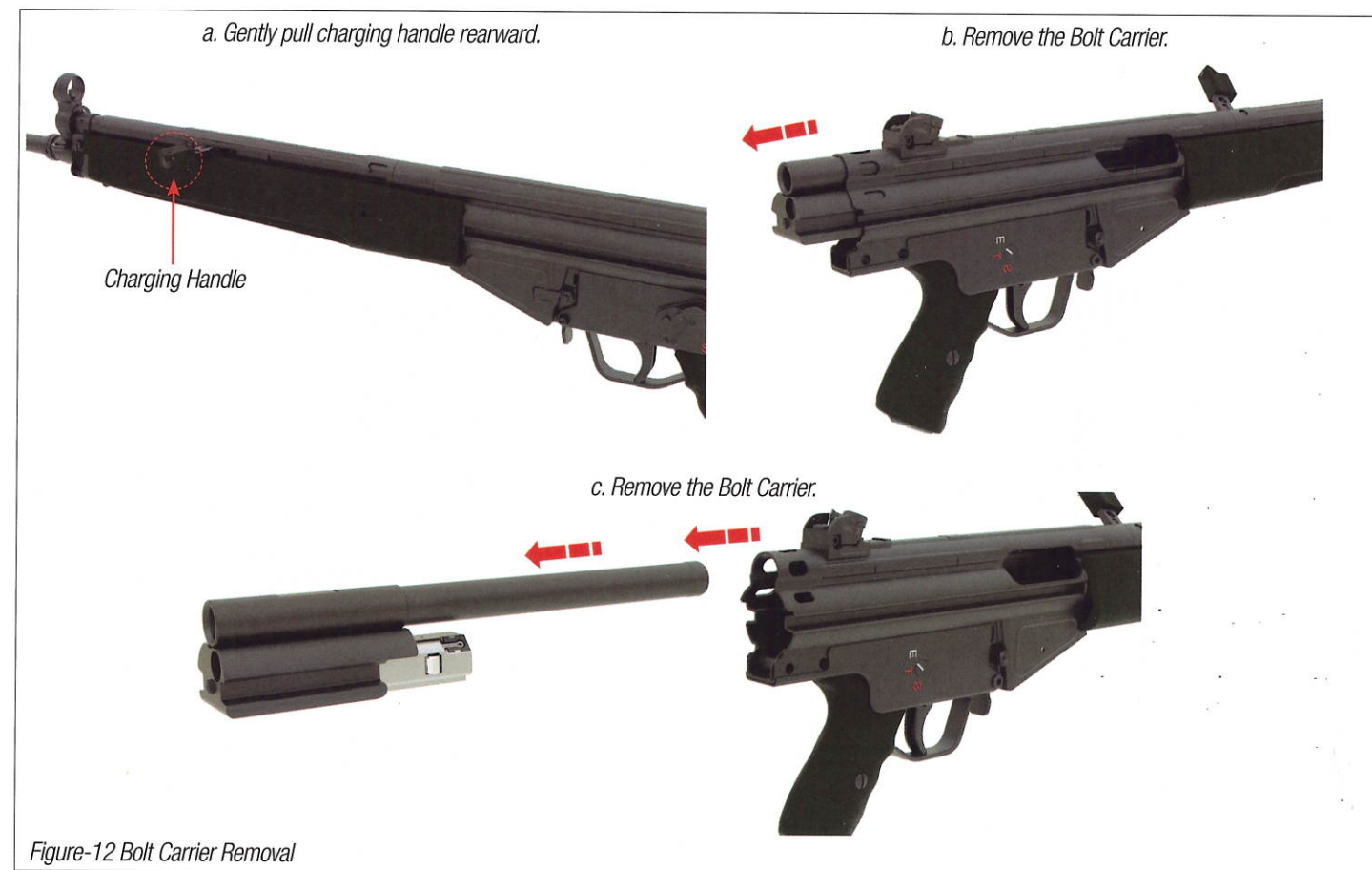

Figure-12 Bolt Carrier Removal

Pull on the charging handle so the bolt carrier assembly comes free from the receiver (see images a, b and c).

4. Grip Removal

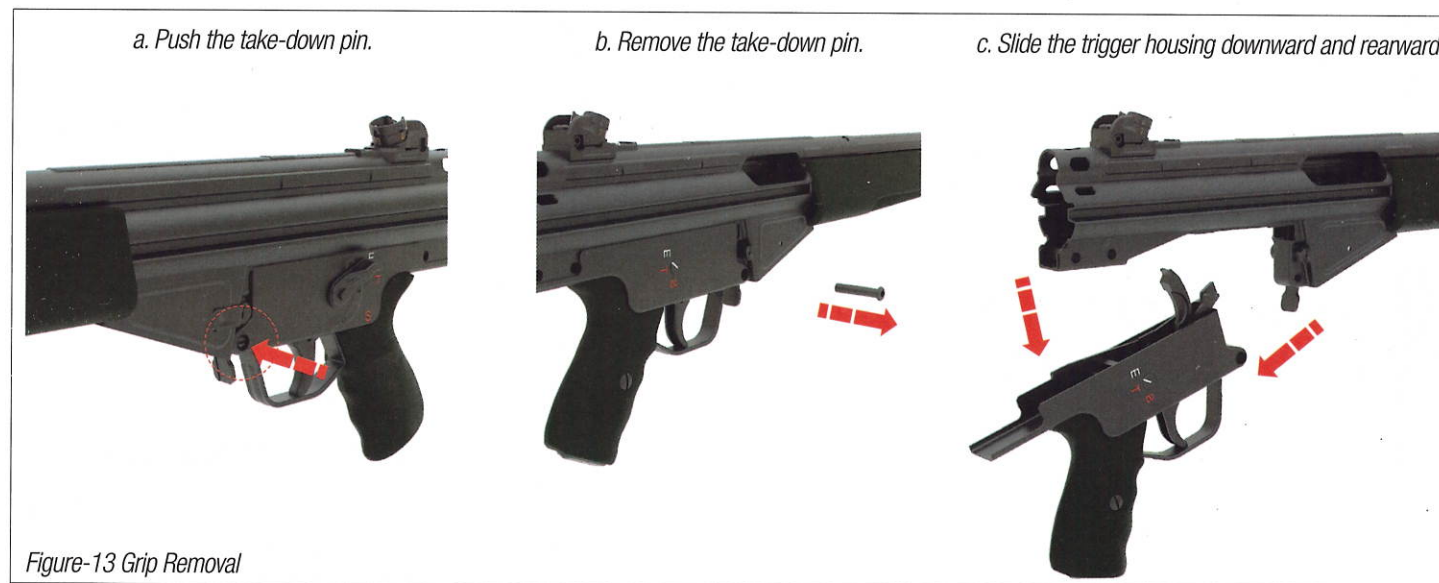

Figure-13 Grip Removal

Push the pin inward (see image a). On the other side of the firearm, remove the pin (see image b). Slide the trigger housing assembly downward and rearward until separated (see image c).

5. Hand Guard Removal

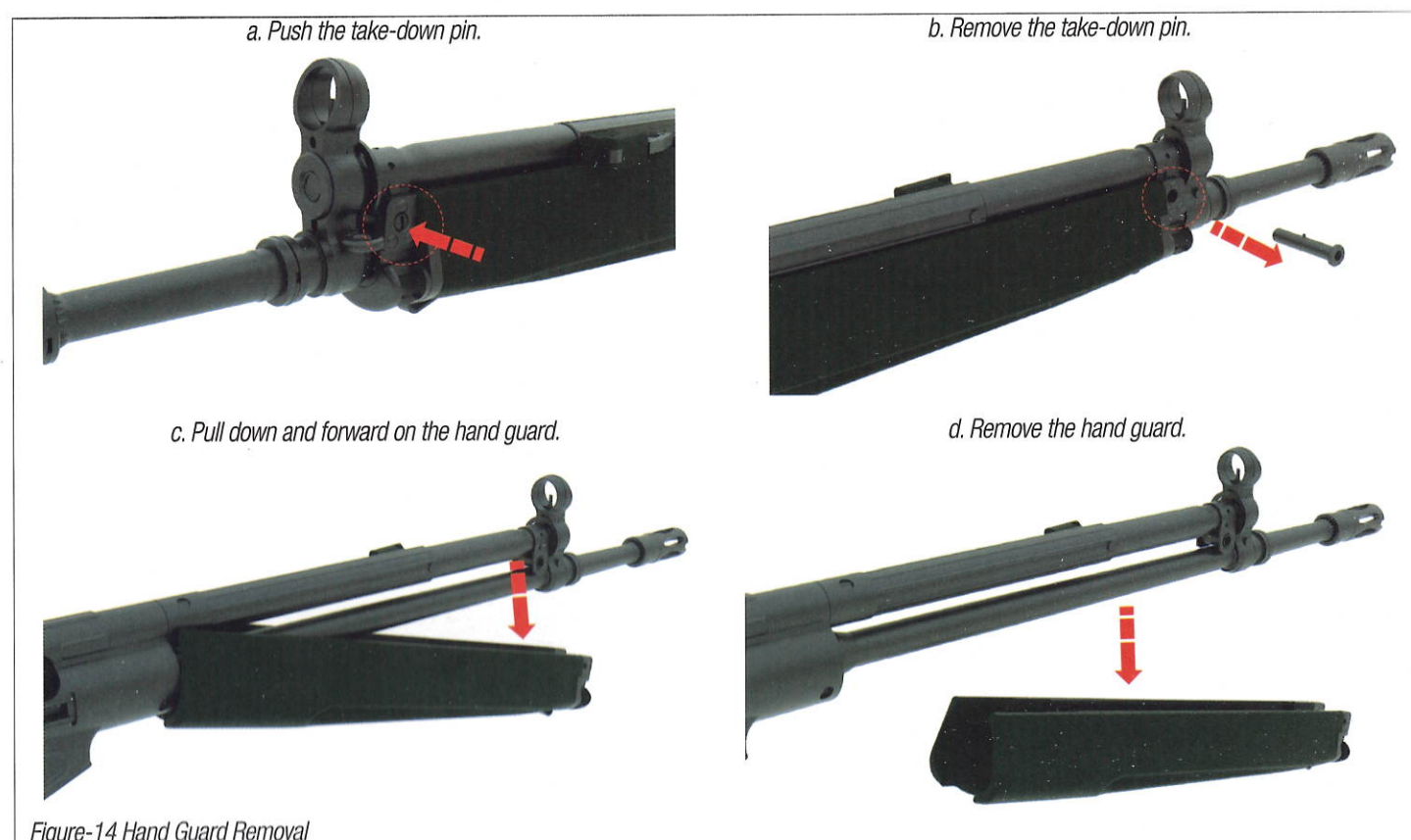

Figure-14 Hand Guard Removal

Push the take-down pin inward (see image a). Remove the take-down pin from the rifle (see image b). Pull down and forward on the hand guard and the hand guard will slide off of the receiver (see image c and d).

G3 AUTOMATIC RIFLE REASSEMBLY

Reassemble the rifle in reverse order of disassembly.



CAUTION: DO NOT USE EXCESSIVE FORCE WHEN DISASSEMBLING, ASSEMBLING OR CLEANING THE FIREARM.



CAUTION: THE BARREL MAY BE HOT IF RECENTLY FIRED.

G3 AUTOMATIC RIFLE OPERATION

Safe and Fire Selector Operation

1. Selecting the Firearm to Safe

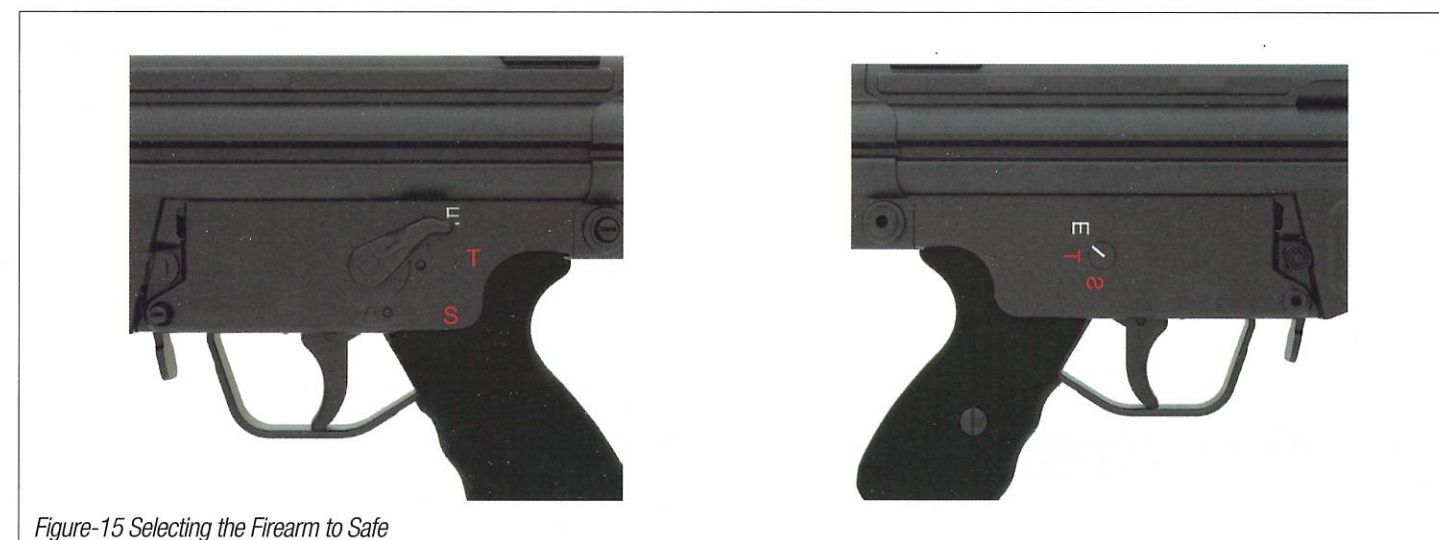

Figure-15 Selecting the Firearm to Safe

To place the firearm on safe, flip the safety lever, located on the left side of the trigger housing, up to "E" (safe). This will lock the trigger and the firearm cannot be fired.

2. Selecting the Firearm to Semi-Auto Fire

a. Single Fire

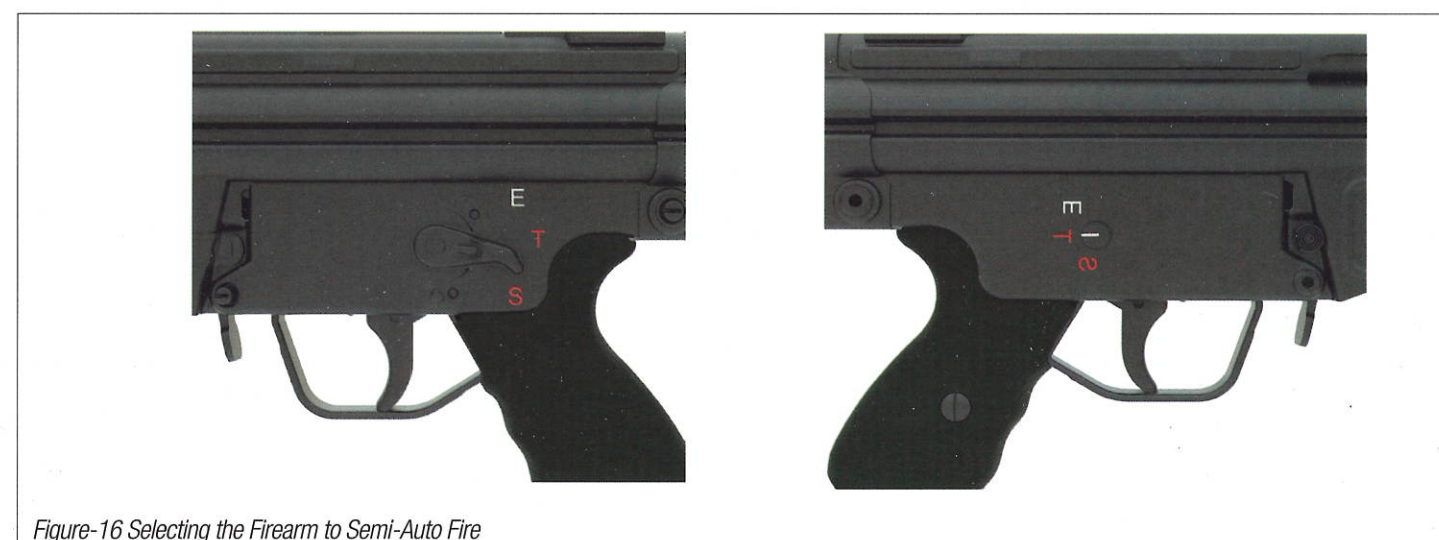

Figure-16 Selecting the Firearm to Semi-Auto Fire

To place the firearm in the fire position, flip the safety lever, located on the left side of the trigger housing, down to "T" (fire) or "1" (1 round). This will select semi-auto fire mode, where one pull of the trigger will fire one round and reload the next round.

b. Automatic Fire

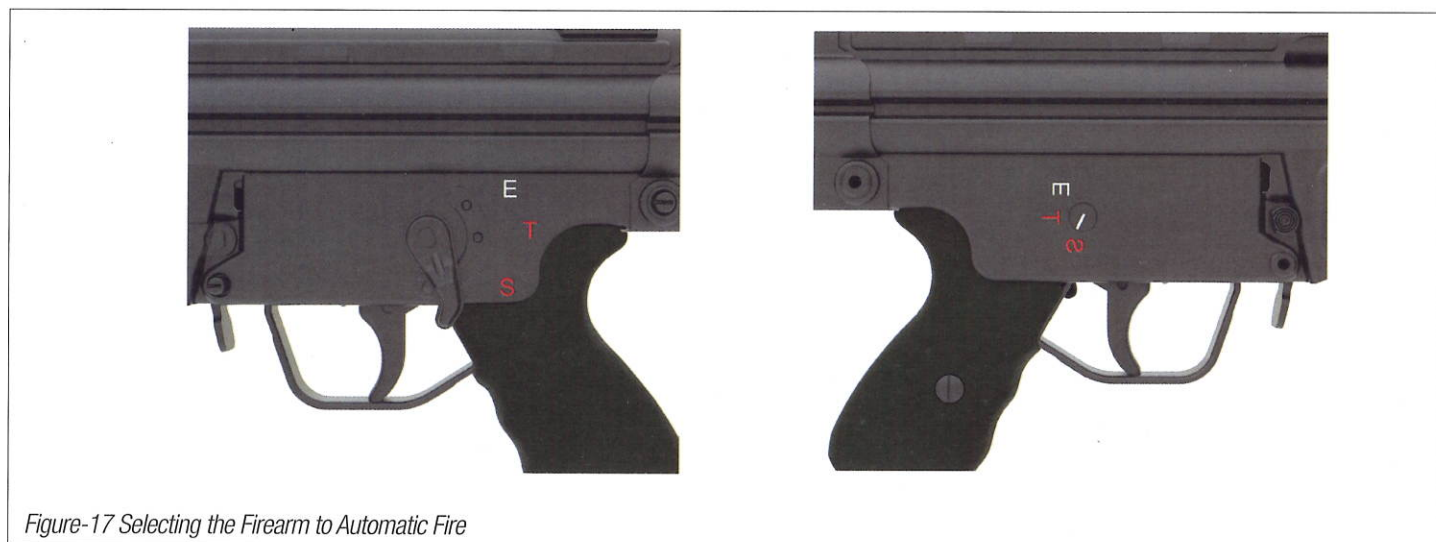

Figure-17 Selecting the Firearm to Automatic Fire

To place the firearm in the fire position, flip the safety lever, located on the left side of the trigger housing, down to "S" (fire). This will select automatic fire mode, where one pull of the trigger will fire more than one round and reload the next round.

Loading and Unloading the Magazine

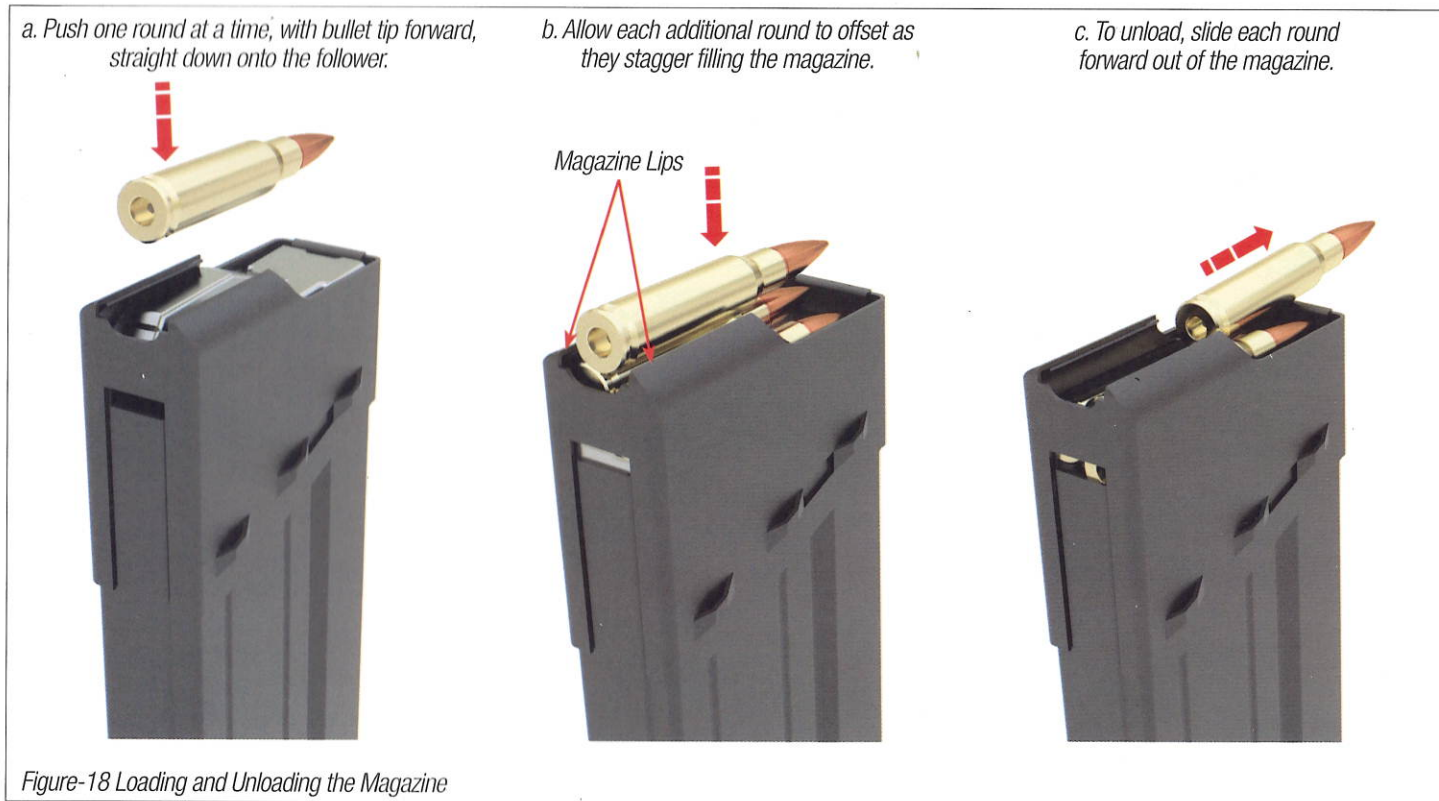

Figure-18 Loading and Unloading the Magazine

1. Loading the Magazine

Firmly grasp the magazine in the weak hand while using the thumb of the strong hand to push the first round between the lips of the magazine onto the follower. Use your thumb to push each additional round straight down, allowing the rounds to stagger as it fills. Ensure the rounds face forward toward the front of the magazine. Do not overload the magazine's capacity.

2. Unloading the Magazine

Firmly grasp the magazine in the weak hand while using the thumb of the strong hand to push the first round forward out from under the lips of the magazine. Continue to use your thumb to push each additional round straight out. Do not attempt to pull the rounds straight up to remove them.



WARNING: NEVER USE DAMAGED OR INCOMPATIBLE AMMUNITION.



WARNING: NEVER USE ANY ITEM THAT MAY INADVERTENTLY STRIKE THE PRIMER WHEN UNLOADING CARTRIDGES FROM THE MAGAZINE.

Loading the Firearm

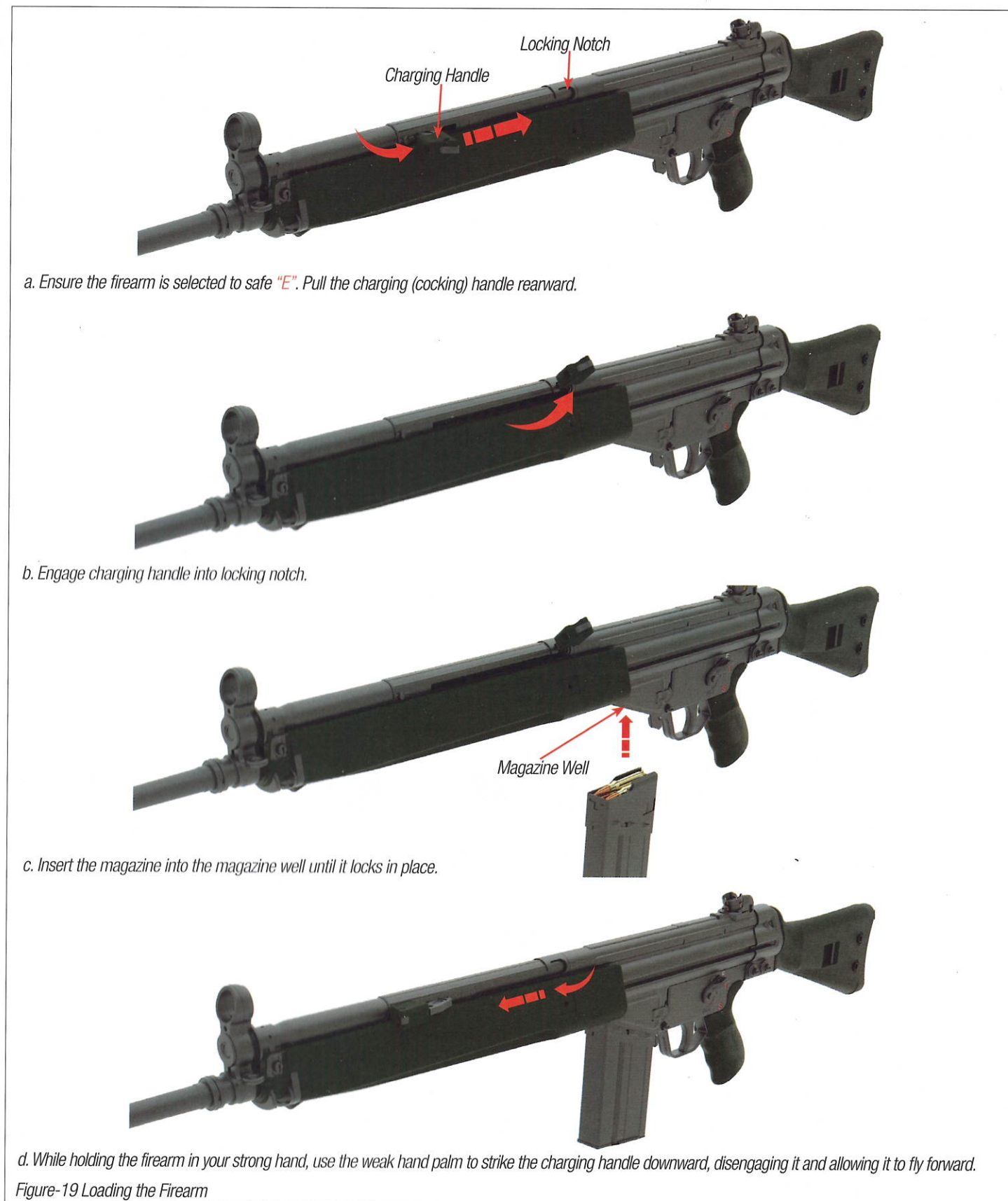

Ensure the firearm safety "E" is engaged. While holding the pistol grip in the strong hand, use the weak hand palm to pull the charging (cocking) handle rearward (see image a). While still holding the cocking handle, pull up and engage into the locking notch (see image b). Using your weak hand insert a loaded magazine into the magazine well, tugging on it to ensure it is locked (see image c). While holding the firearm in your strong hand, use the weak hand palm to strike the charging handle downward, disengaging it and allowing it to move freely forward (see image d). The firearm is now loaded and ready to fire. Moving the selector switch to fire will enable semi-auto fire.



CAUTION: WHEN RELEASING THE CHARGING HANDLE, BE SURE TO AVOID PINCHING HAZARDS AS IT IS UNDER PRESSURE FROM THE RECOIL SPRING.



CAUTION: IT IS IMPORTANT TO ALLOW THE CHARGING HANDLE TO MOVE FREELY FORWARD UNDER SPRING TENSION.



CAUTION: DO NOT ATTEMPT TO EASE THE CHARGING HANDLE FORWARD AS THIS MAY CAUSE A MISFEED.

Unloading the Firearm

Put the trigger safety lever in "E" (safe).
 Press the magazine button to remove magazine.
 Face the casing ejecting window to the floor.
 Pull the cocking handle back to remove the cartridge in the chamber.
 Look at the casing ejecting window and chamber, and check if there is a cartridge or empty casing, manually and visually.
 The firearm is now empty.

Firearm Operating System

The weapon is loaded and cocked, and ready to fire (Figure-20 Firearm Operating System-1).

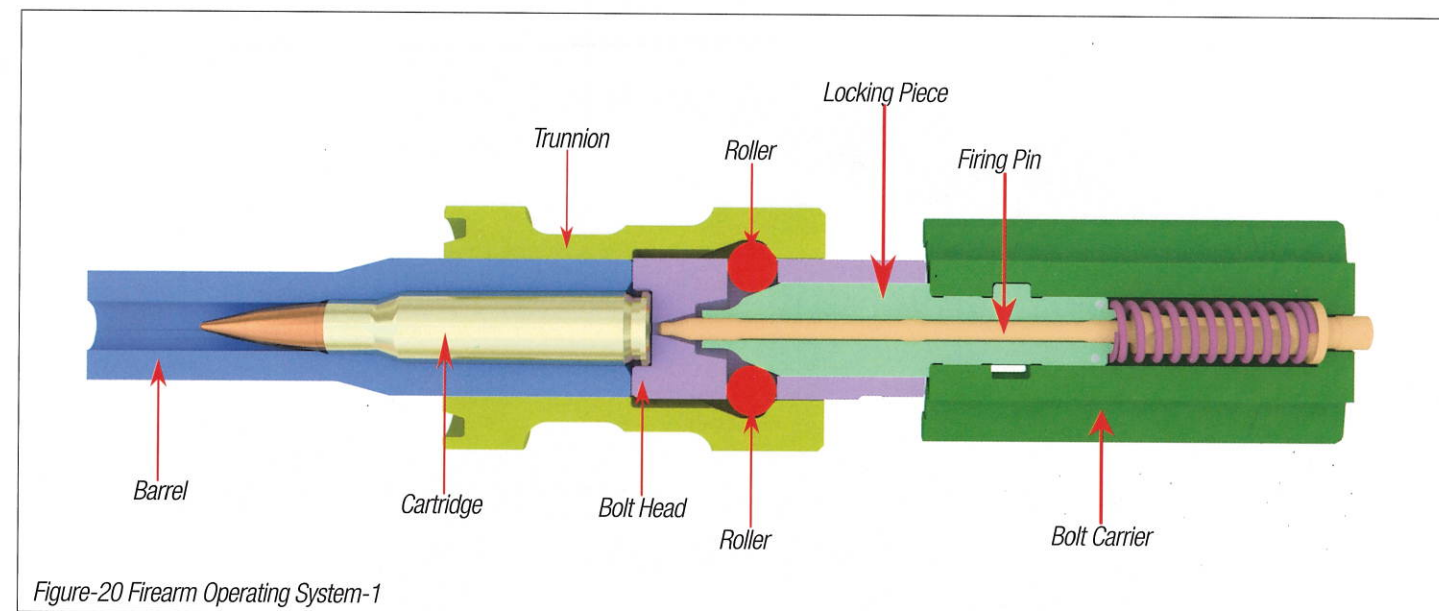

By pulling the trigger the cocked hammer is released and strikes the firing pin which fires the cartridge with its point. The powder gas drives the projectile down the barrel. At the same time powder gasses are forced against the cartridge case. The cartridge case transmits a part of the gas pressure to the bolt head and there by the backward movement is initiated (Figure-21 Firearm Operating System-2).

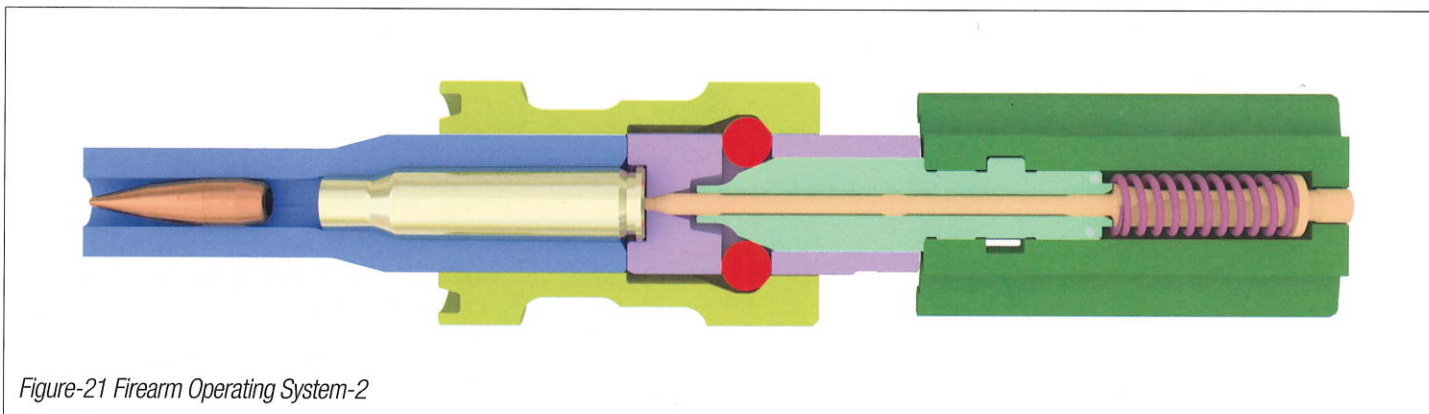

Figure-21 Firearm Operating System-2

Thus the bolt head carrier is activated by means of the locking rollers and the locking piece in the proportion 1:4 on which occasion the locking rollers remain locked until the bullet has left the barrel. The locking rollers emerge from the recesses in the barrel extension and are pressing against the inclined faces of the locking piece. The locking piece slides back and the locking rollers slip into the bolt head as far as necessary to unlock the bolt (Figure-22 Firearm Operating System-3).

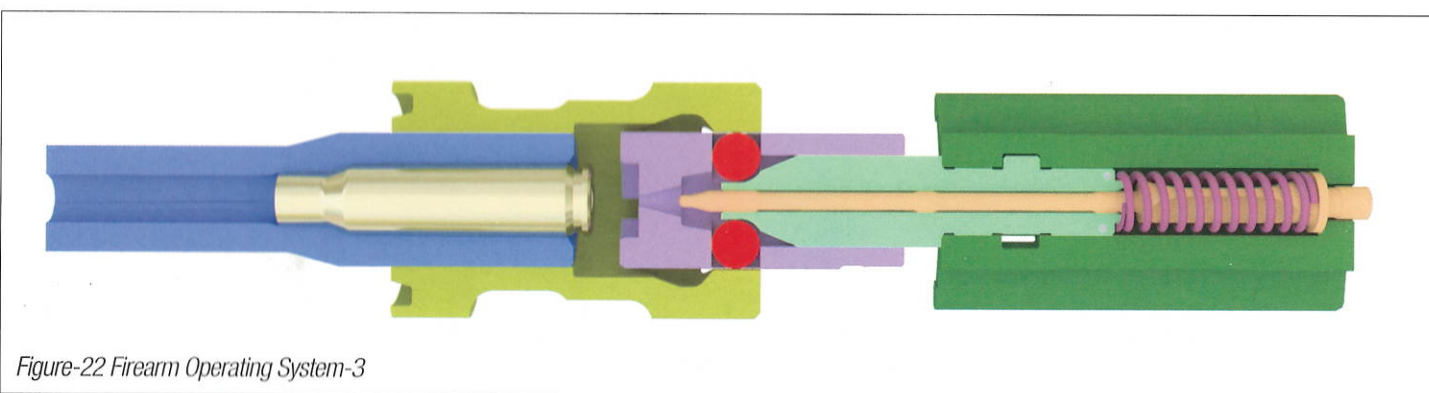

Figure-22 Firearm Operating System-3

The locking piece with its shoulders hits the bolt head carrier and gives additional speed at the same time. While sliding to the rear the locking lever disengages from the bolt head. Bolt head and bolt head carrier separate themselves to a distance of about 5 mm but move further backwards together (Figure-23 Firearm Operating System-4).

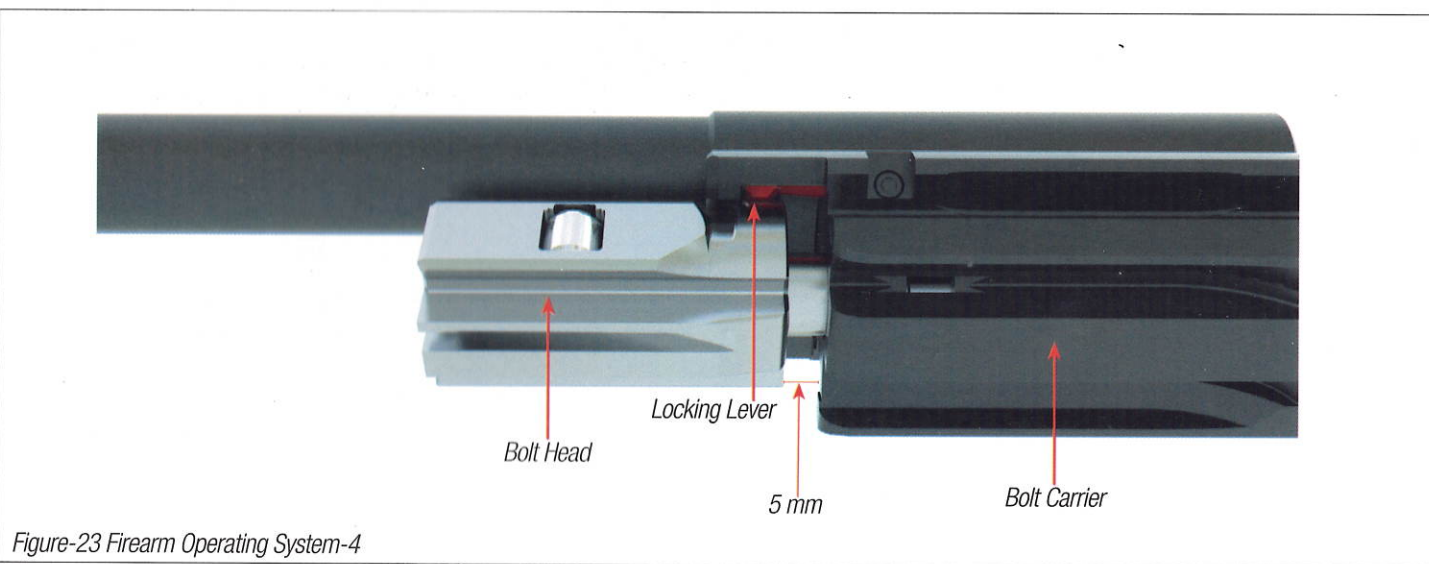

Figure-23 Firearm Operating System-4

While the bolt head is moving backwards the hammer is cocked, the recoil spring compressed, the cartridge case held by the extractor thus hits the ejector and is ejected. In its rearmost position the bolt hits the buffer and is stopped (Figure-24 Firearm Operating System-5).

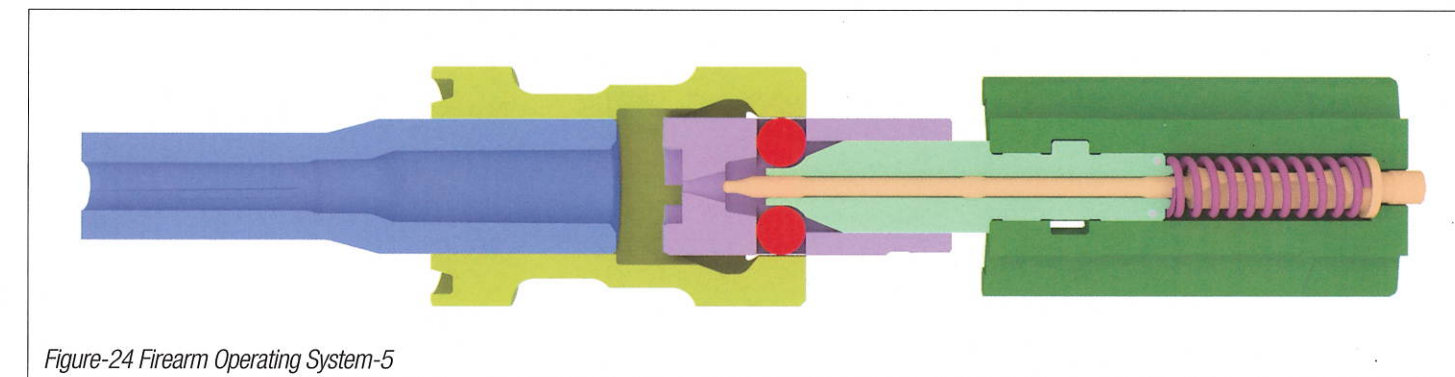

Figure-24 Firearm Operating System-5

At the forward movement the energy of the expanding recoil spring and the expanding buffer spring pushes the bolt forward. The cartridge on top in the magazine is inserted into the chamber by the front surface of the bolt head. The extractor hooks into the ring groove of the base of the cartridge case. The locking piece with its declining faces pushes the locking rollers outwards until they support themselves in the barrel extension, which locks the weapon (Figure-25 Firearm Operating System-6).

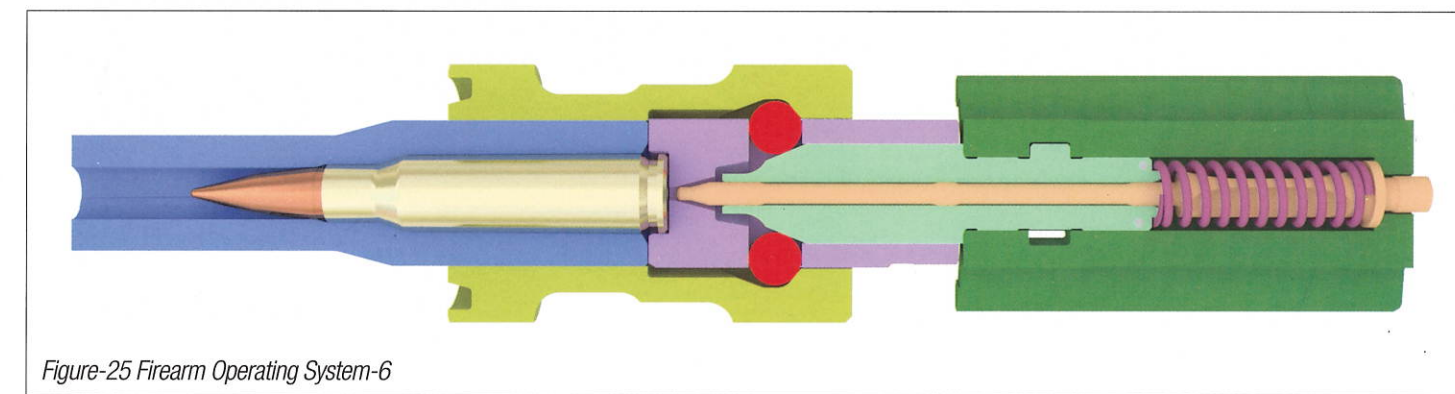

Figure-25 Firearm Operating System-6

At the moment the locking takes place the locking lever steps in front of the shoulder of the bolt head and prevent the bolt head to rebound. The weapon is once more ready to the fire (Figure-26 Firearm Operating System-7).

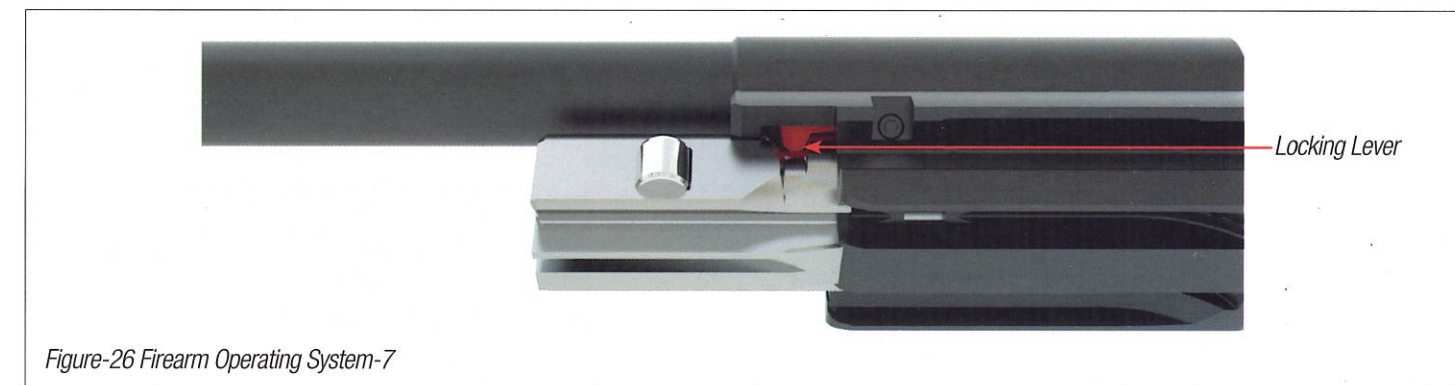

Figure-26 Firearm Operating System-7

Trigger Operating System

The weapon is loaded and the hammer is cocked. The safety lever is at "E" safe.

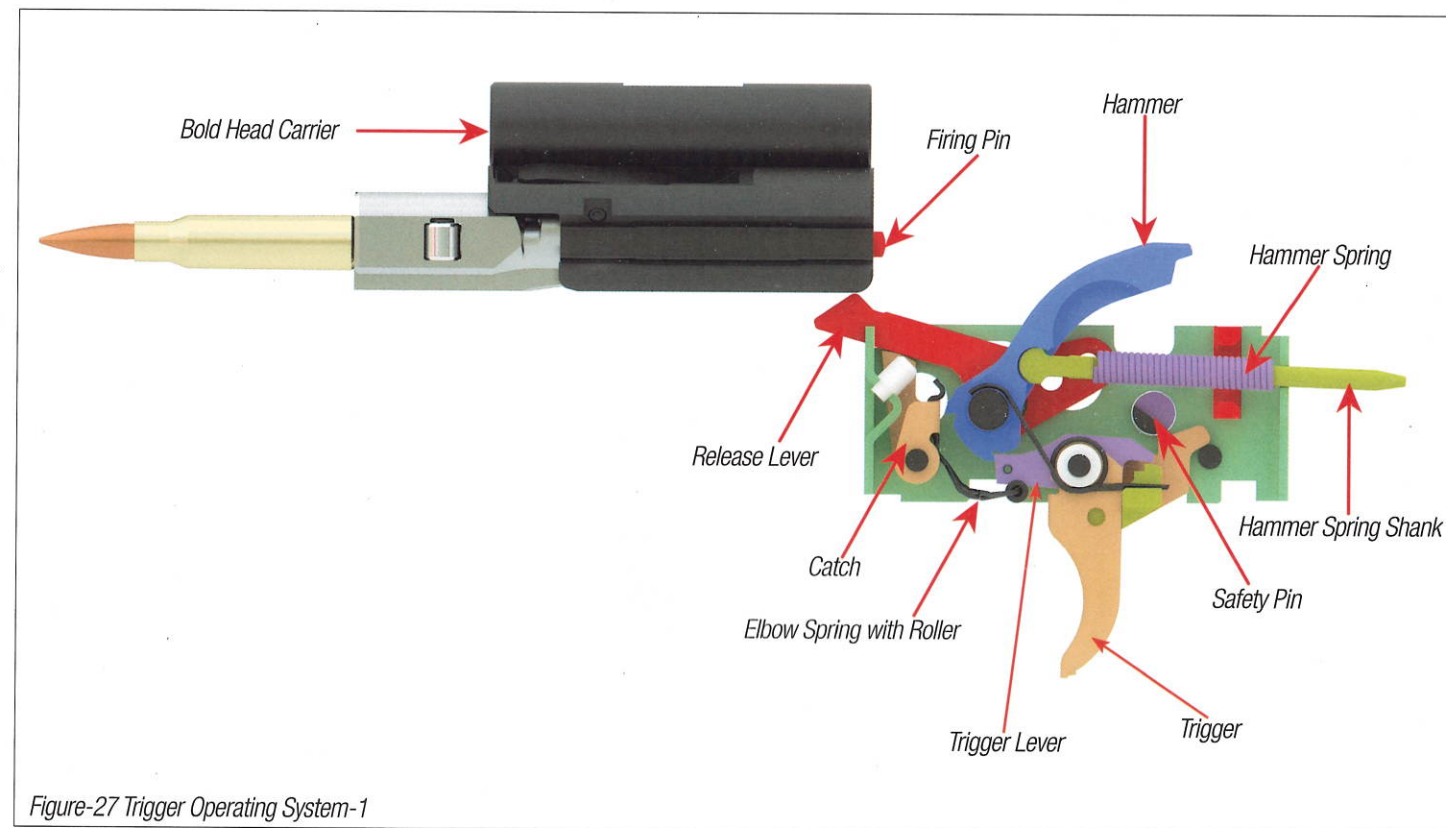

Figure-27 Trigger Operating System-1

Before Firing

The safety lever put on position "T" single fire. At single fire the trigger lever in connection with its oblong hole, the safety pin, the elbow spring with roller, the catch for single fire and the catch for trigger lever as disconnecter comes into action (Figure-28 Trigger Operating System-2).

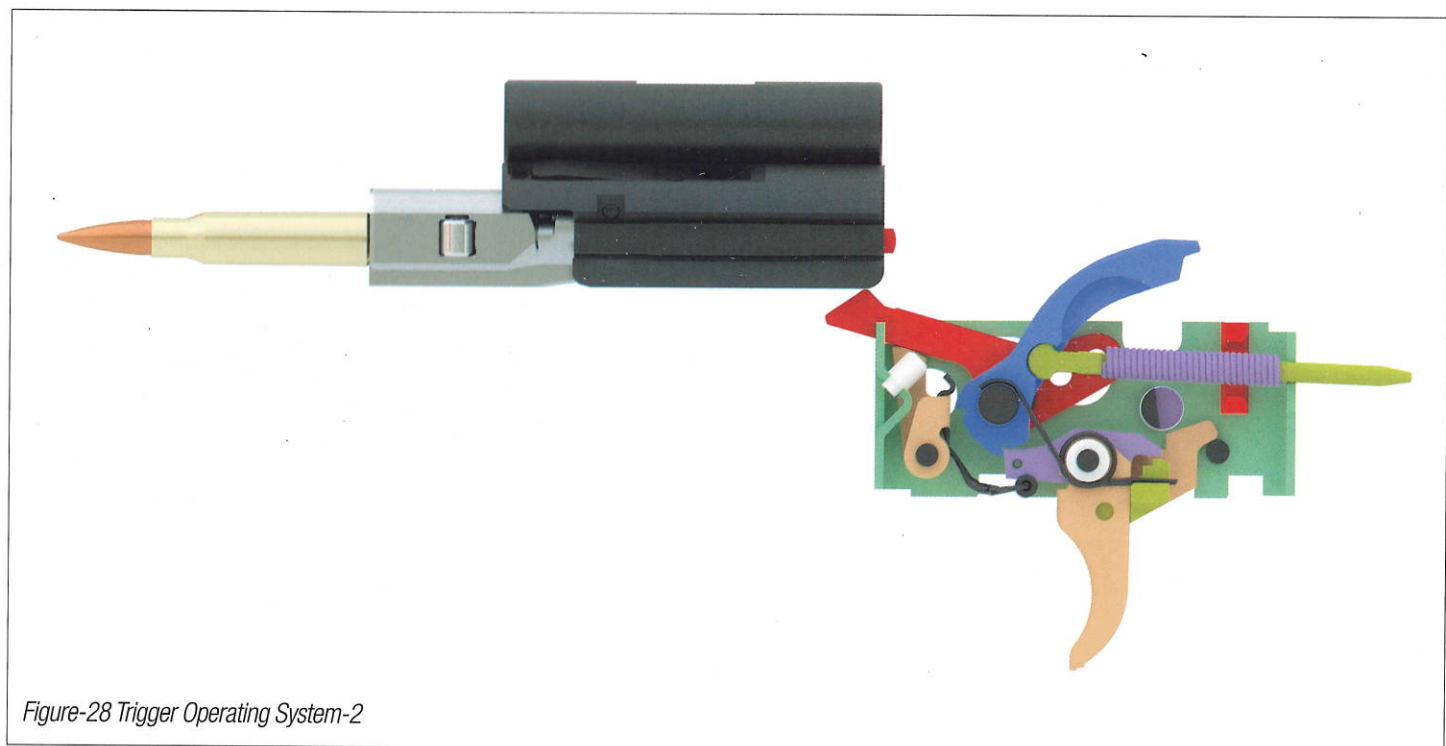

Figure-28 Trigger Operating System-2

The trigger lever with its oblong hole can be shifted about 1.5 mm in its longitudinal direction. In unoperated position, which means without pressure from the hammer, the trigger lever is steadily being pushed forward by means of its pressure bolt with spring. As soon as the hammer with its single fire notch comes in connection with the trigger lever, the latter is pushed backwards overcoming the power of the pressure bolt and its spring. This short longitudinal movement causes a single shot. The catch with its roller pushes at single fire the trigger lever steadily against the hammer notch (Figure-29 Trigger Operating System-3).

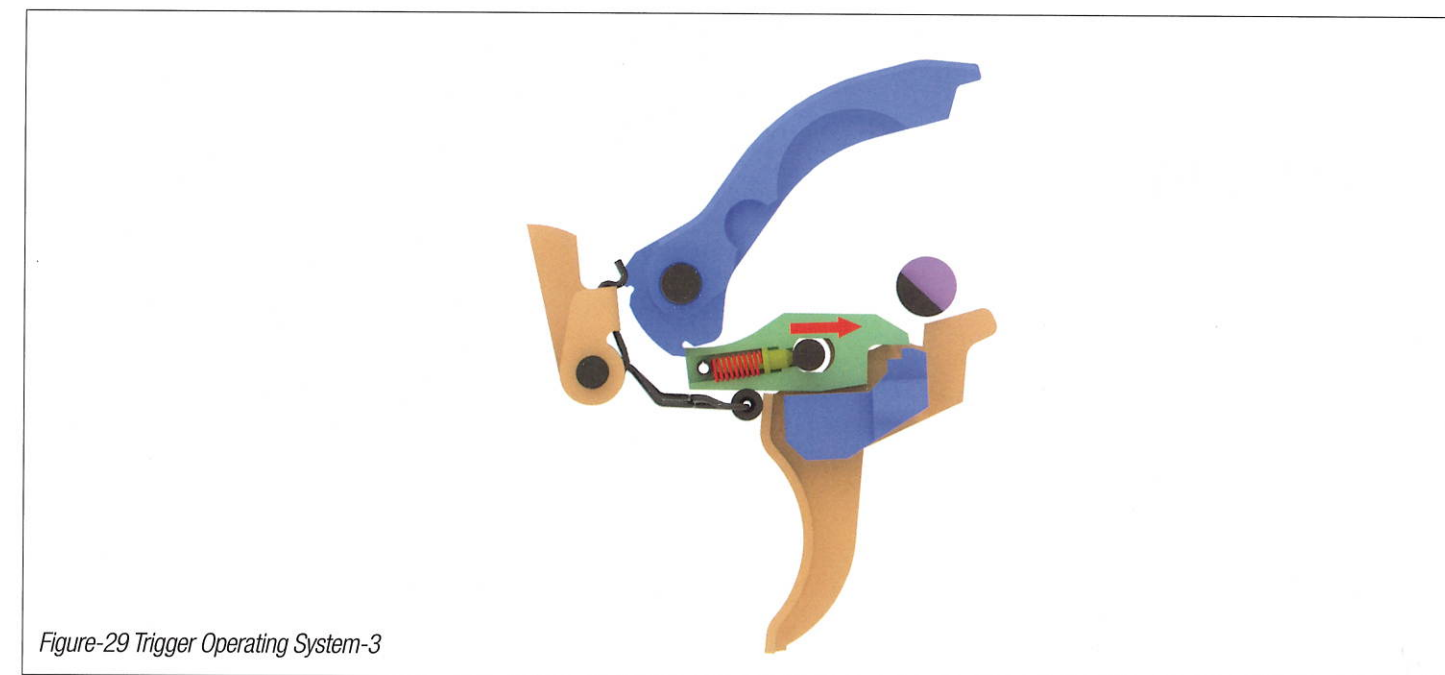

Figure-29 Trigger Operating System-3

Single Fire

The bolt body presses the release lever and thus the sear catch forward the hammer is only retained by the trigger lever (Figure-30 Trigger Operating System-4).

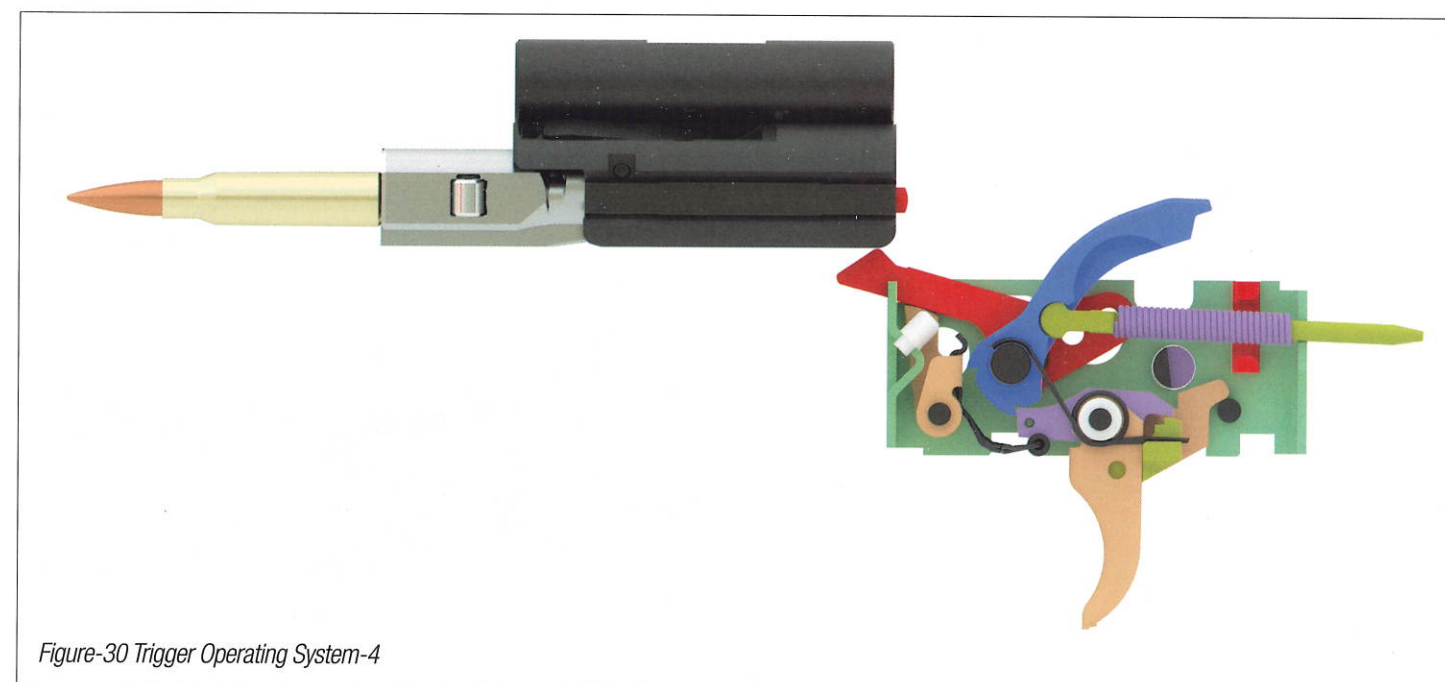

Figure-30 Trigger Operating System-4

When pulling the trigger its extending lever with its recess reaches into the Groove of the safety pin, limiting the movement of the trigger. At the same time the rear part of the trigger lever is being lifted, the front parts lowers and disengages from the single fire notch (Figure-31 Trigger Operating System-5).

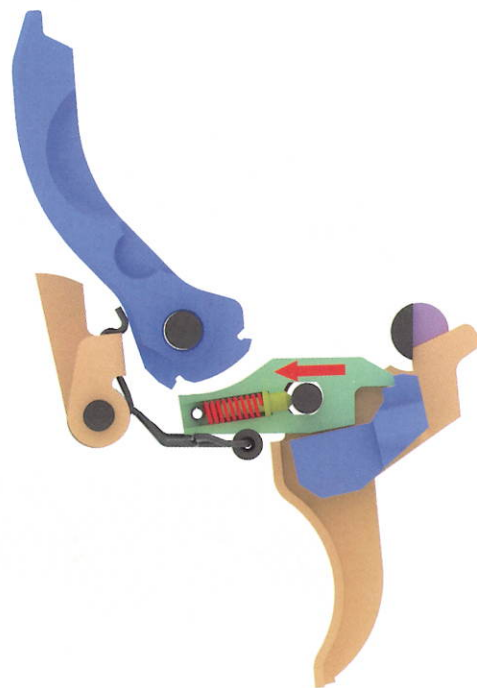

Figure-31 Trigger Operating System-5

The hammer is released, hits the firing pin and fires the cartridge. At this moment the pressure on the trigger lever coming from the hammer is being taken off and the trigger lever goes forward (Figure-32 Trigger Operating System-6).

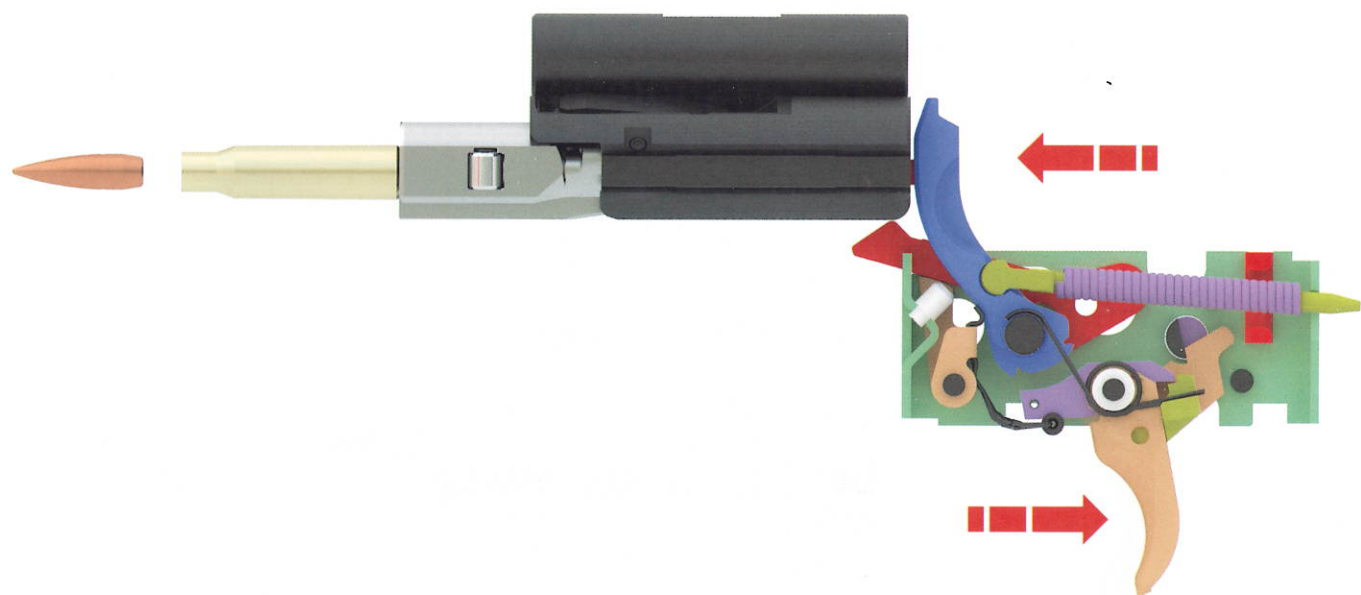

Figure-32 Trigger Operating System-6

Backward Movement

After the cartridge has left the barrel, the bolt goes back and the bolt head carrier pushes the hammer backwards. First the hammer engages in the notch for single fire, shortly thereafter the sear catch engages in the notch for burst. At the first engagement the trigger lever moves backwards, at the second engagement it comes forward again (Figure-33 Trigger Operating System-7).

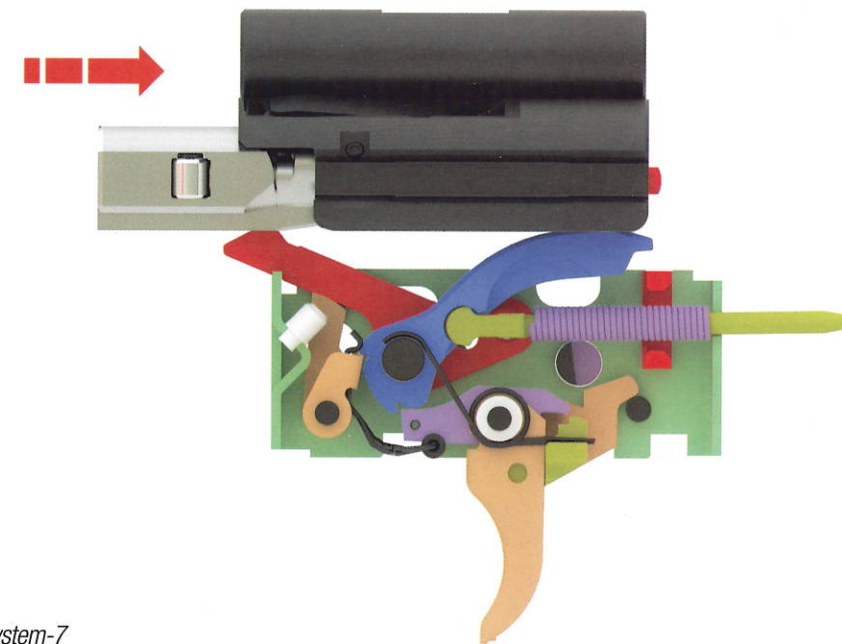

Figure-33 Trigger Operating System-7

Forward Movement

The bouncing off from the buffer and the pressure of the releasing recoil make the bolt head carrier move forward. The climbing ramp of the bolt head carrier presses the release lever downwards which releases the catch (Figure-34 Trigger Operating System-8).

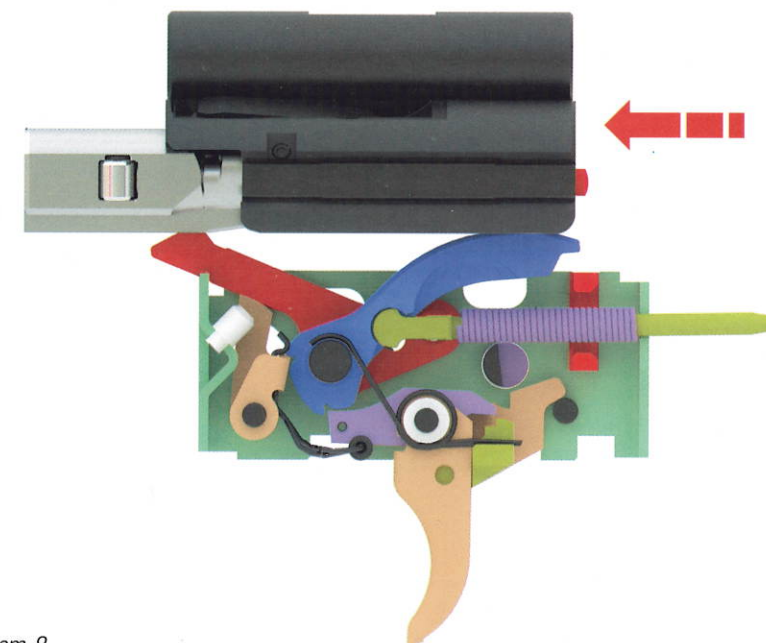

Figure-34 Trigger Operating System-8

The hammer cannot strike but is caught on the trigger lever. The trigger lever is jammed between the notch for single fire and the trigger lever notch (Figure-35 Trigger Operating System-9).

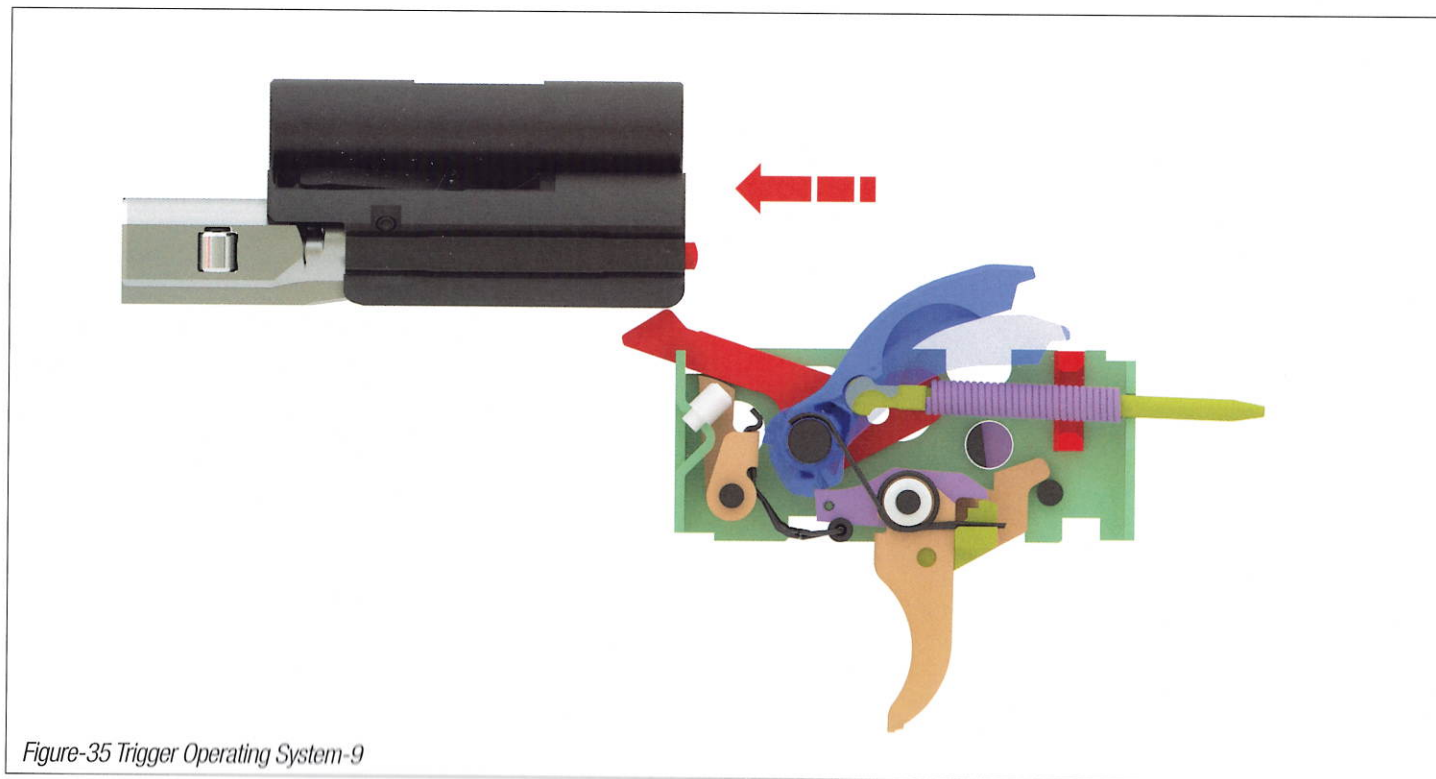

Figure-35 Trigger Operating System-9

In this position the sequence is interrupted. To fire another shot, the trigger must be released. After the trigger is released, the trigger lever comes down and releases the rear part of the trigger lever. Due to the pressure from the hammer the trigger lever is pushed back, as far as the longitudinal hole makes it possible and rests over the pull-off surface, the condition for the next shot is given. Should another shot be fired the trigger is pulled until the pull-off. Further pull of the trigger lifts the rear part of the trigger lever, while the front part disengages from the notch for single fire. The cartridge is fired and all functions repeat themselves.

Automatic Fire

A turn of the safety lever to "S" burst also turns the safety pin which brings the Groove in front of the extended trigger arm (Figure-36 Trigger Operating System-10).

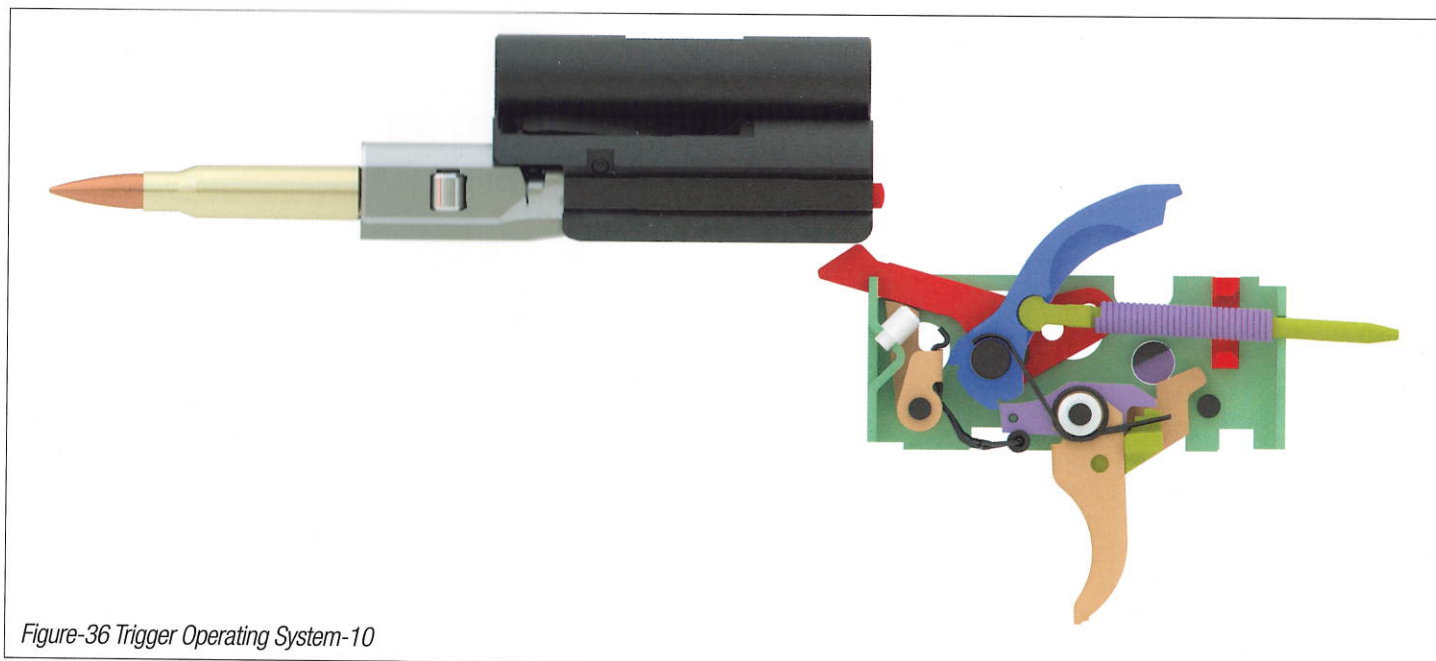

Figure-36 Trigger Operating System-10

When the shooter pulls the trigger, all of the extended arm enters in the Groove of the safety pin, causing a longer trigger pull and the trigger lever is out of reach of the notch for single fire (Figure-37 Trigger Operating System-11).

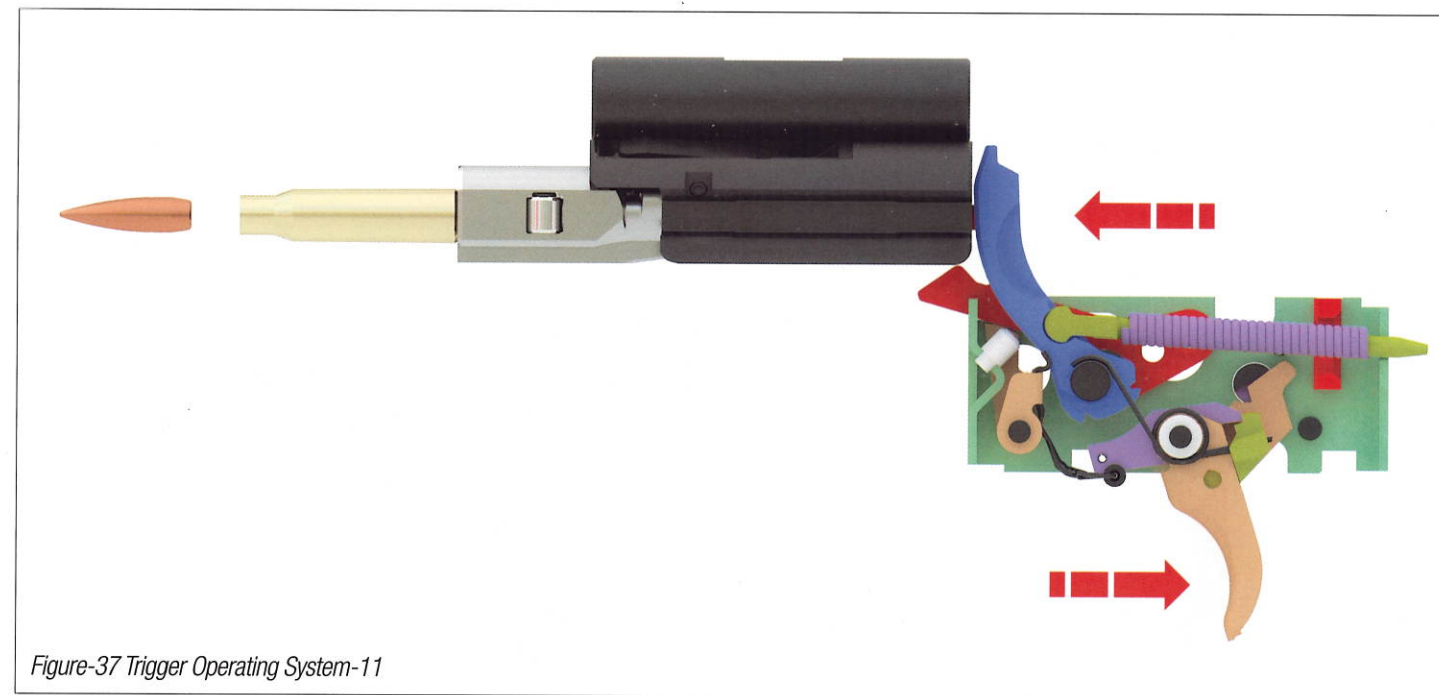

Figure-37 Trigger Operating System-11

The hammer is held only by the catch in the notch for burst. With every shot release lever makes a guided motion caused by the climbing ramp of the bolt head carrier and the catch emerges from the notch for burst (Figure-38 Trigger Operating System-12).

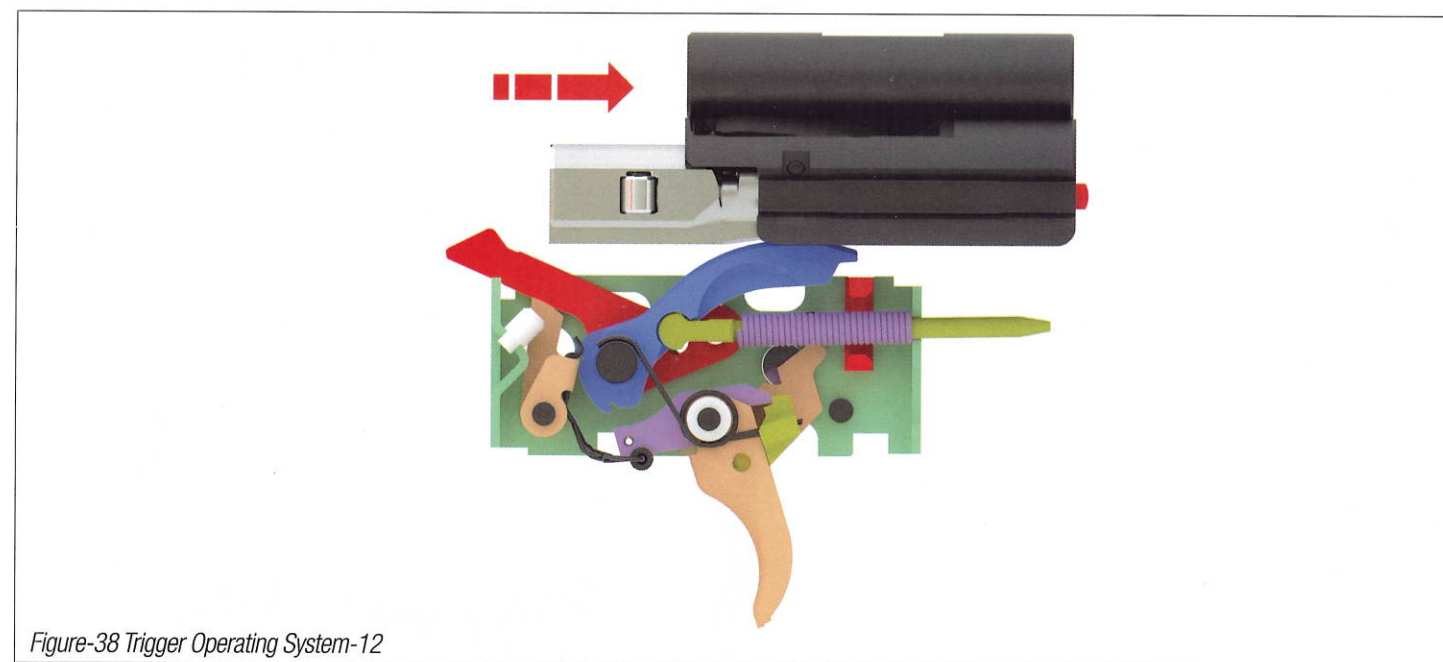

Figure-38 Trigger Operating System-12

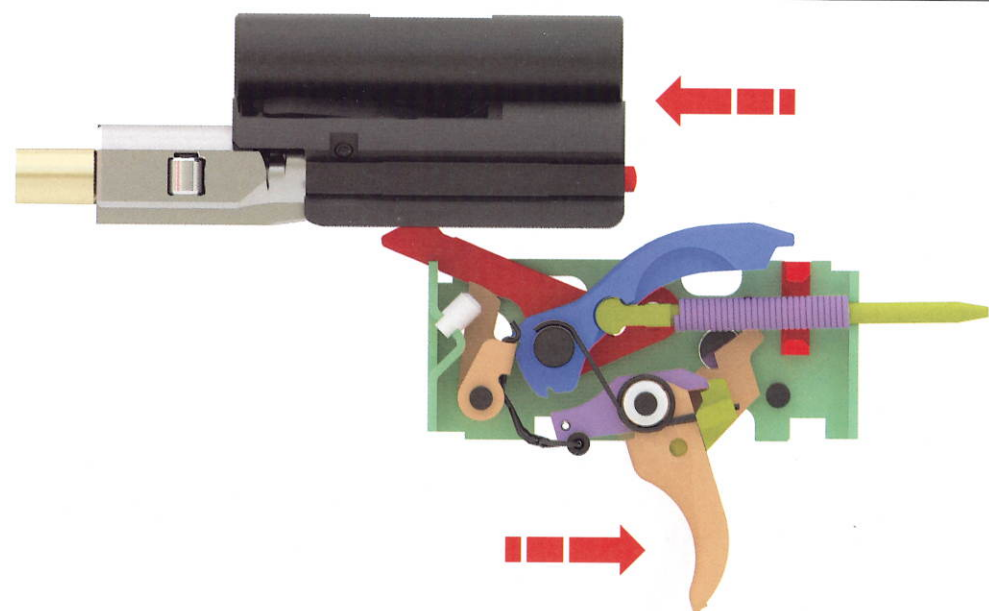

Figure-39 Trigger Operating System-12

The hammer strikes the firing pin, as nothing interferes to its motion. This sequence is called automatic fire. Short interruptions of the automatic fire result in bursts. The weapon ceases firing when the trigger is released. The front part of the trigger swings up again and the hammer is caught in the notch for single fire (Figure-40 Trigger Operating System-13).

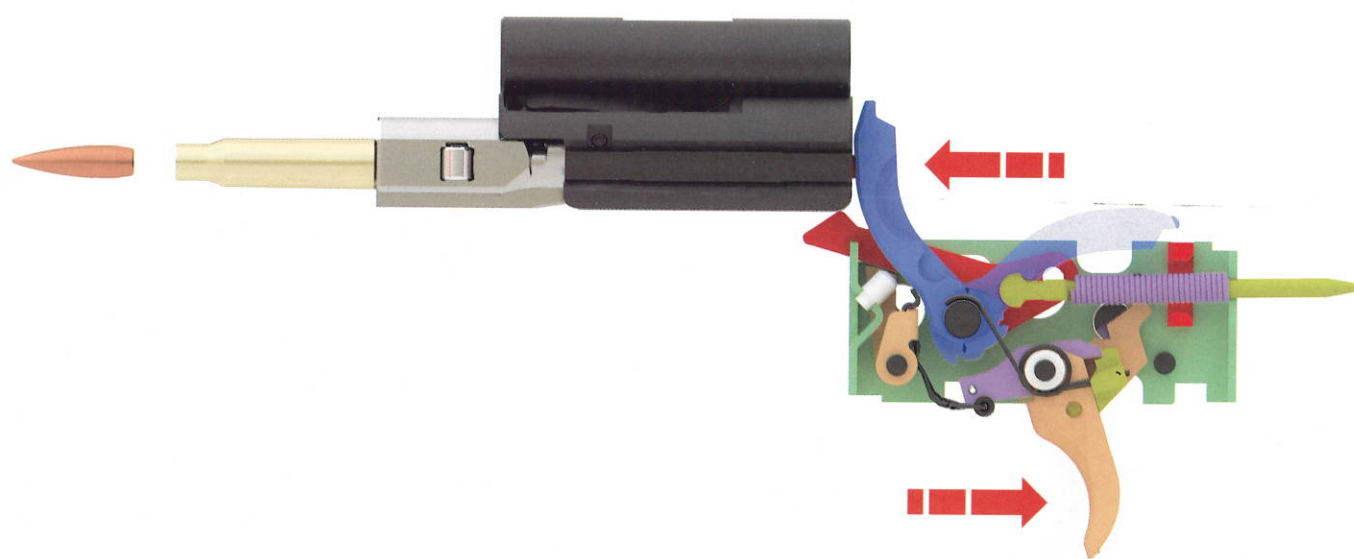
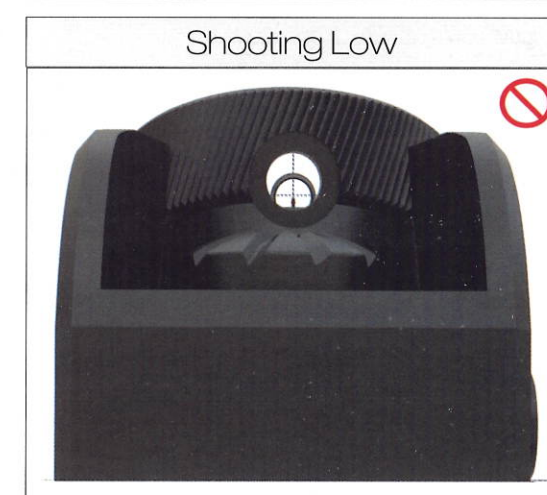
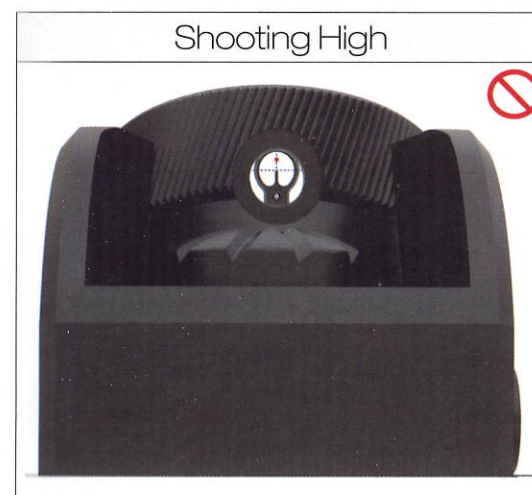
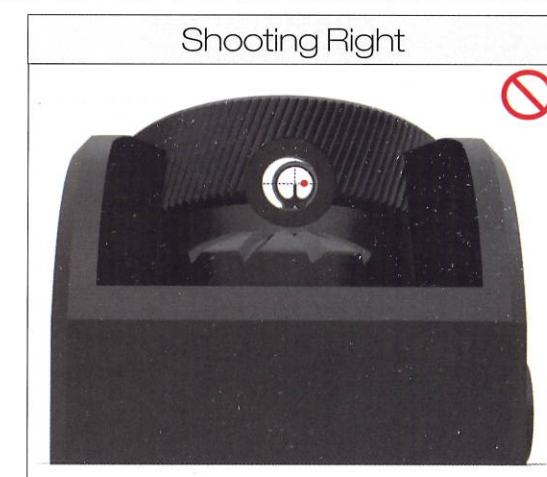
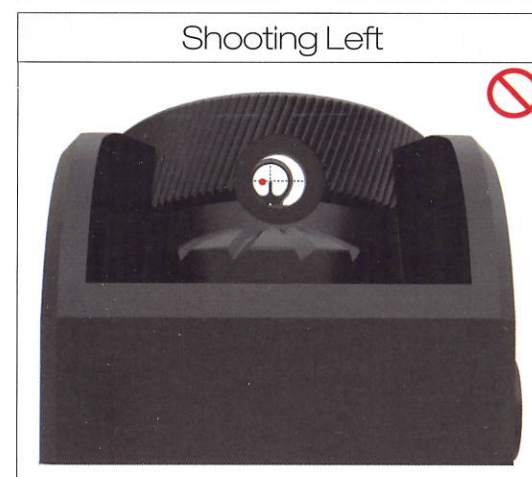
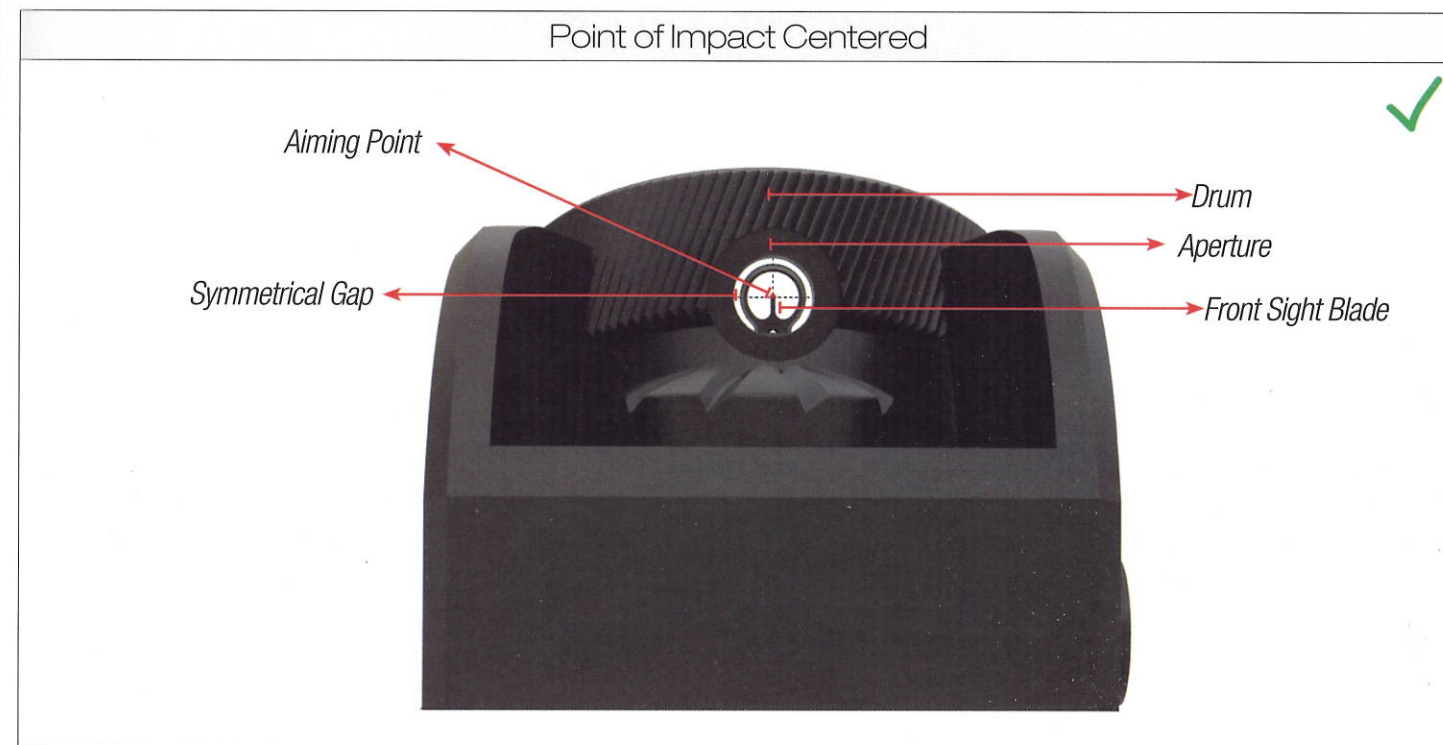

Figure-40 Trigger Operating System-13

G3 AUTOMATIC RIFLE SIGHTS

Using the Sights

The rear sight has four apertures labeled 1, 2, 3, and 4. The number 1 has a V-notch designed for shooting up to 100 meters. The numbers 2, 3, and 4 represent 200, 300, and 400 meters.





Rear Sight Adjustments

G3 Rifles are zeroed after production. If the sight requires adjustment for elevation or windage, this is done in the following manner.

Windage Adjustment

To adjust the windage to the left, loosen the locking screw and gently turn the adjustment counter-clockwise. To adjust the windage to the right, loosen the locking screw and gently turn the adjustment clockwise. One quarter turn (one click) equals approximately 1.18 inch change in elevation or windage at 100 yards.



Figure-41 Windage Adjustment

Elevation Adjustment

Elevation adjustment is made by use of an elevation adjustment tool. The elevation adjustment tool engages in the notches on the inside of the drum sight. All adjustments should be made with the rear drum placed on the #1. Turning the drum clockwise will lower the bullet's point of impact. Turning the drum counter-clockwise will raise the bullet's point of impact. One quarter turn (one click) equals approximately 1.18 inch change in elevation or windage at 100 yards.

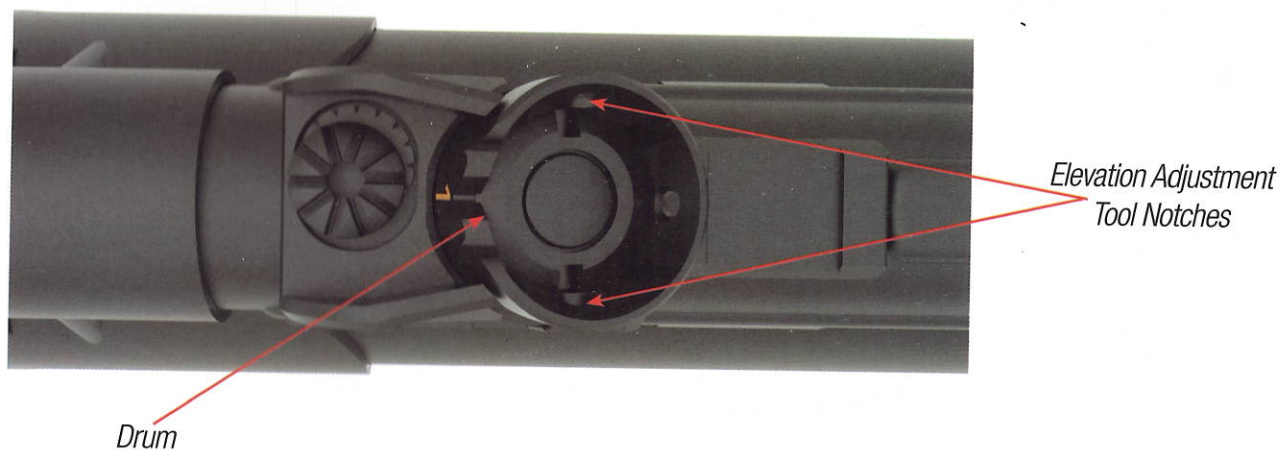

Figure-42 Elevation Adjustment



CAUTION: IT IS RECOMMENDED TO USE A SIGHT ADJUSTMENT TOOL FOR ADJUSTING ELEVATION.



FIREARM MAINTENANCE

Regular Maintenance

Always be aware of the overall operation of your firearm. Ensure the charging handle, safety selector, magazine insertion, etc. are in proper operating condition. If any strong resistance or odd tolerances are noted, investigate. In general keep your firearm clean and lubricated. When your firearm is disassembled, inspect for rust, corrosion, and build up of any residues that will affect operation. A function check should be performed. This entails ensuring the safety does not allow the trigger to be pulled.

Prior to Use

Perform a regular maintenance and function check prior to use. Pay special attention to ensure there are no obstructions or mechanical situations that need to be addressed.

After Each Use

After each firing session, the firearm should be unloaded, checked for clear, and field stripped. The firearm should then be cleaned, re-lubricated, and subjected a function check prior to storing.

Extreme Climate Maintenance

High Heat and Humid/Wet Conditions

In climates with high heat and humidity the firearm, and especially its internal components, can rust more quickly. Inspect your firearm more often and never leave components without lubrication. If any rust or corrosion is located, clean it off and re-lubricate immediately.

High Heat and/or Low Humidity/Dry Conditions

In climates with high heat and/or low humidity, firearms are less likely to rust, however, lubrication can evaporate and dirt, sand, and other contaminants can find their way into the operation. This will cause faster wear and abrasion of the internal components. Use a thinner oil and wipe all excess oil after cleaning, as excess oil will attract and hold dirt.

Extreme Cold Conditions

In climates with extreme cold and/or low humidity, the lubricating oils used should be selected specifically for this environment. Sudden temperature changes can cause moisture build-up inside the firearm leading to corrosion. For this reason attention must be paid for condensation both inside and out. Care must be taken to not place a hot, recently fired firearm in snow or ice as it could damage or deform metal surfaces. And upon transitioning from a cold environment to a warm environment condensation will occur and must be addressed with drying and lubrication.

Disassembly and Maintenance of Bolt Carrier

Disassembly of Bolt Carrier Assembly

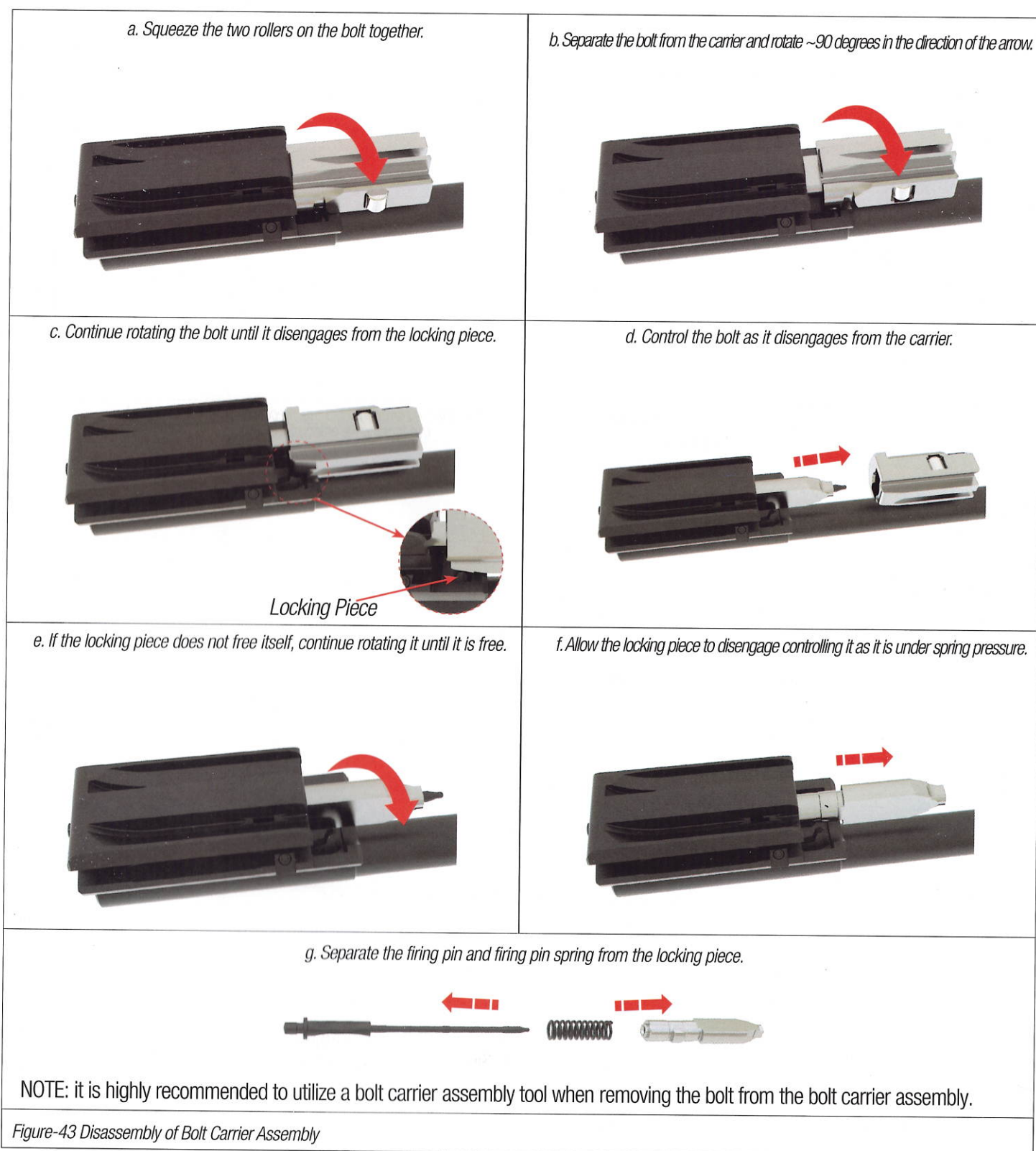

Squeeze the two rollers together (see image a), pull the bolt away from the bolt carrier (see image b), and rotate the bolt ~90 degrees counter-clockwise (see image c). Control the bolt allowing it to separate from the carrier (see image d). Holding the locking piece firmly, continue to turn it until it unlocks and comes free of the carrier (see image e). Control the removal of the locking piece including the firing pin and firing pin spring (see figure f). Separate the firing pin and firing pin spring from the locking piece (see image g).

Maintenance of Bolt Carrier Assembly

Once disassembled the bolt carrier should be cleaned to remove all carbon and unburned powder. Solvent and a brush may be used. After cleaning, a light coat of lubricant should be applied to all surfaces. Reassemble in reverse order from disassembly.

Bolt Carrier Reassembly

Once cleaned, follow the reassembly show below.

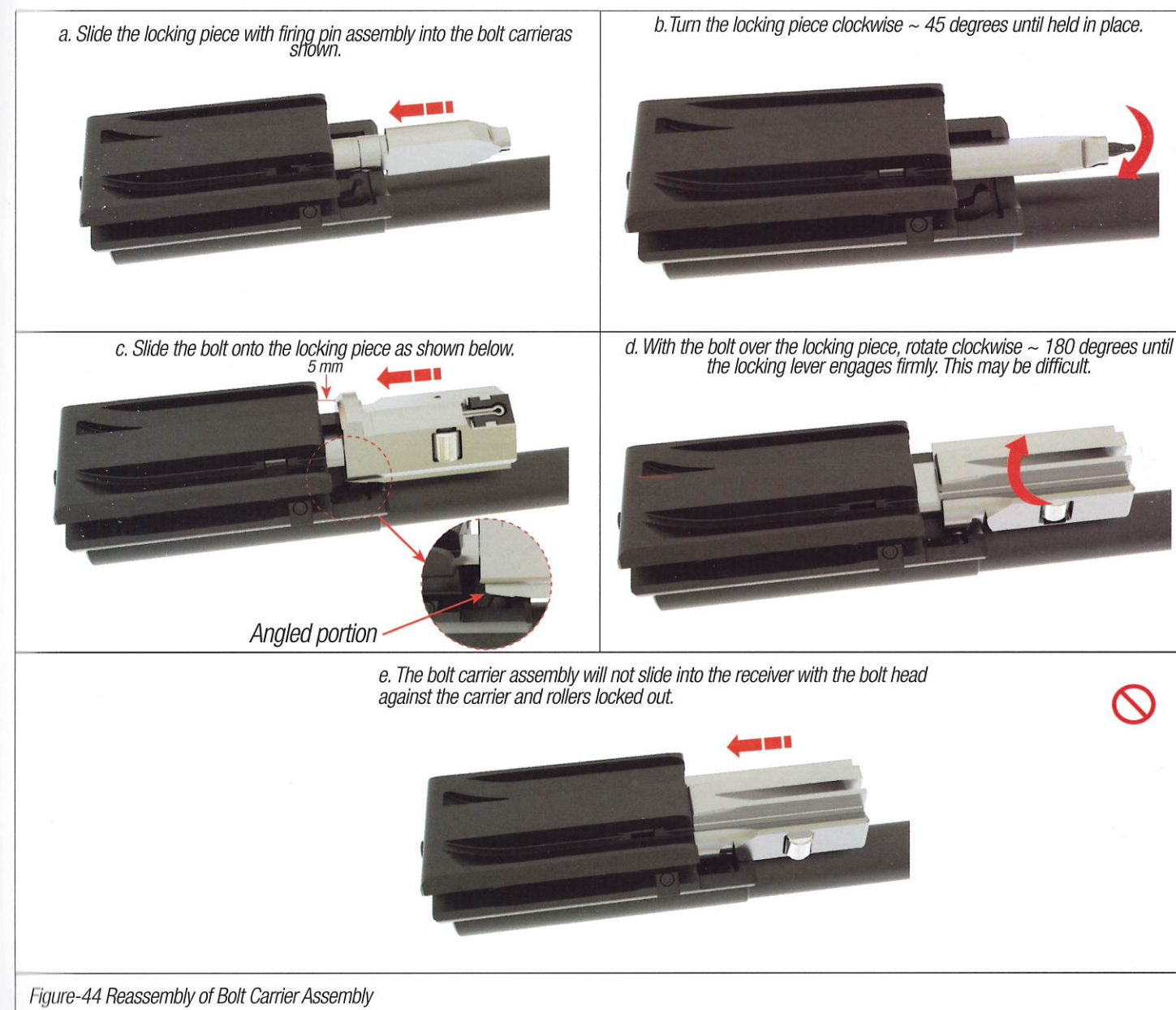

Slide the locking piece, including the firing pin assembly, into the bolt carrier (see image a). Turn the locking piece clockwise ~45 degrees until held in place (see image b). Slide the bolt over the locking piece and rotate clockwise ~180 degrees until the locking lever engages (see image c and d). Continue to rotate the bolt head over the locking piece ~5 mm from the carrier so that the rollers remain unlocked (see image e).



CAUTION: THE BOLT CARRIER ASSEMBLY WILL NOT SLIDE INTO THE RECEIVER WITH THE BOLT HEAD FLUSH AGAINST THE CARRIER AND ROLLERS LOCKED OUT. YOU MUST MAINTAIN A~5 MM GAP BETWEEN THE TWO (SEE IMAGE F).

NOTE: A BOLT CARRIER ASSEMBLY TOOL IS HIGHLY RECOMMENDED FOR THE ABOVE PROCEDURES.

Trigger Pack Removal and Maintenance

Trigger Housing Removal

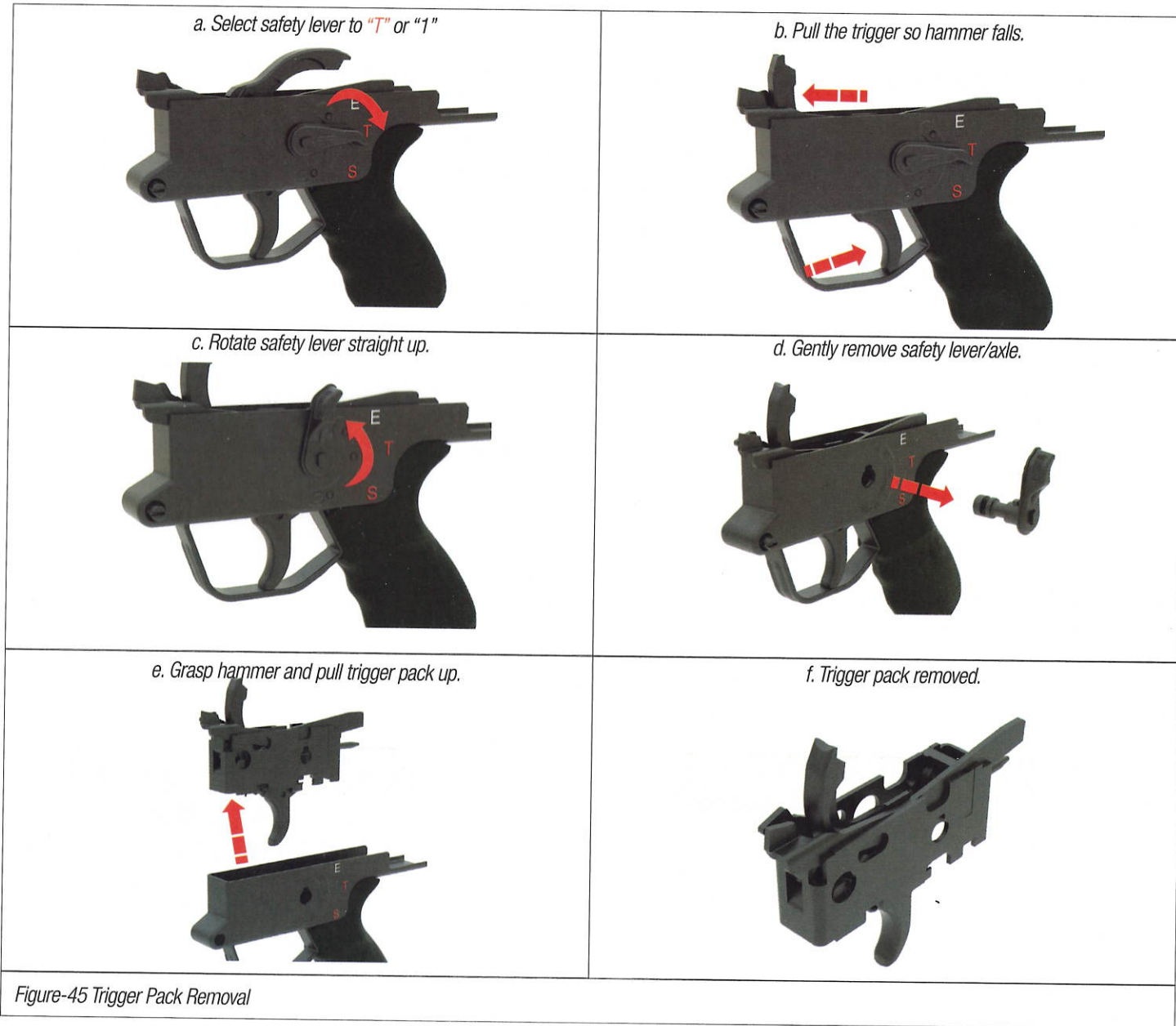

Select safety lever to "T" or "1" (see image a). Pull the trigger so hammer falls (see image b) using the offhand to prevent it from falling freely. Rotate safety lever straight up (see image c). Gently remove safety lever/axle (see image d). Grasp hammer and pull trigger pack up (see image e).

Trigger Pack Maintenance

The trigger pack can be removed during regular cleaning. Once removed, inspect for dirt, sand, unburned powder, or any other debris. Any debris can be removed by brush or compressed air. It is recommended that a certified armorer initiate disassembly of the trigger pack.

USING THE MULTI-PURPOSE CARRYING SLING

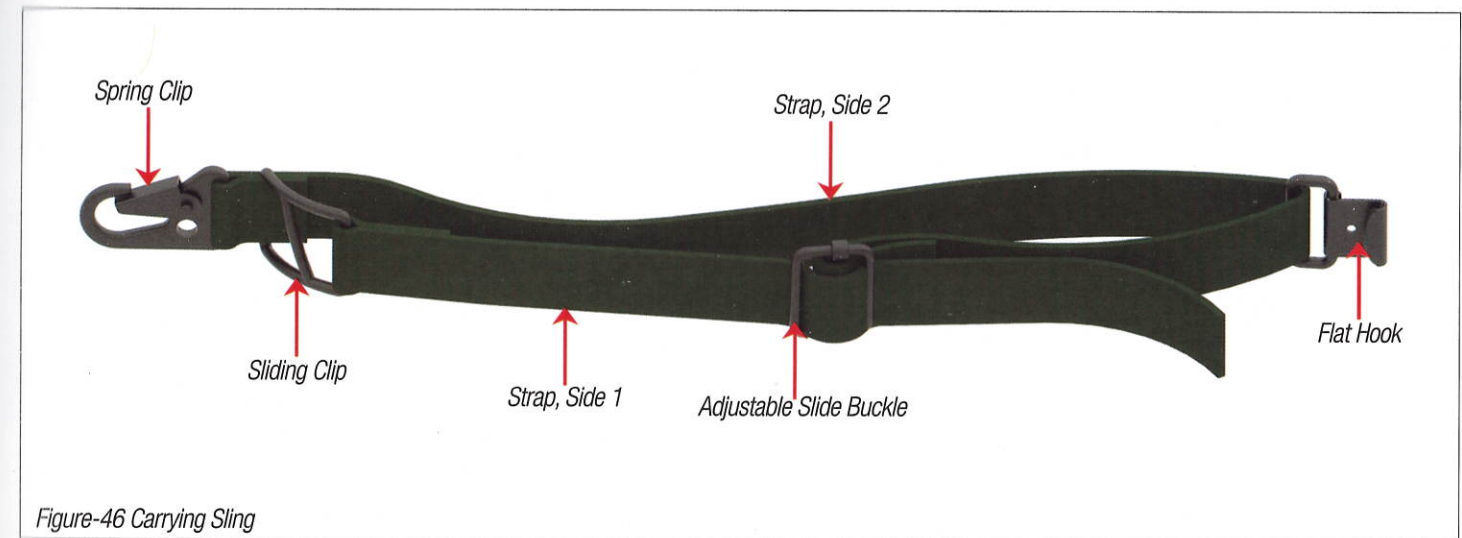

Set the multi-purpose carrying sling to the proper length for the individual shooter by readjusting the sliding buckle. The correct sling length can be checked by assuming the desired firing position.

When slinging the weapon, one half of the sling 1 should extend over the shooters back, with the other half 2 resting across his chest.

Putting the Carrying Sling in to the Firearm

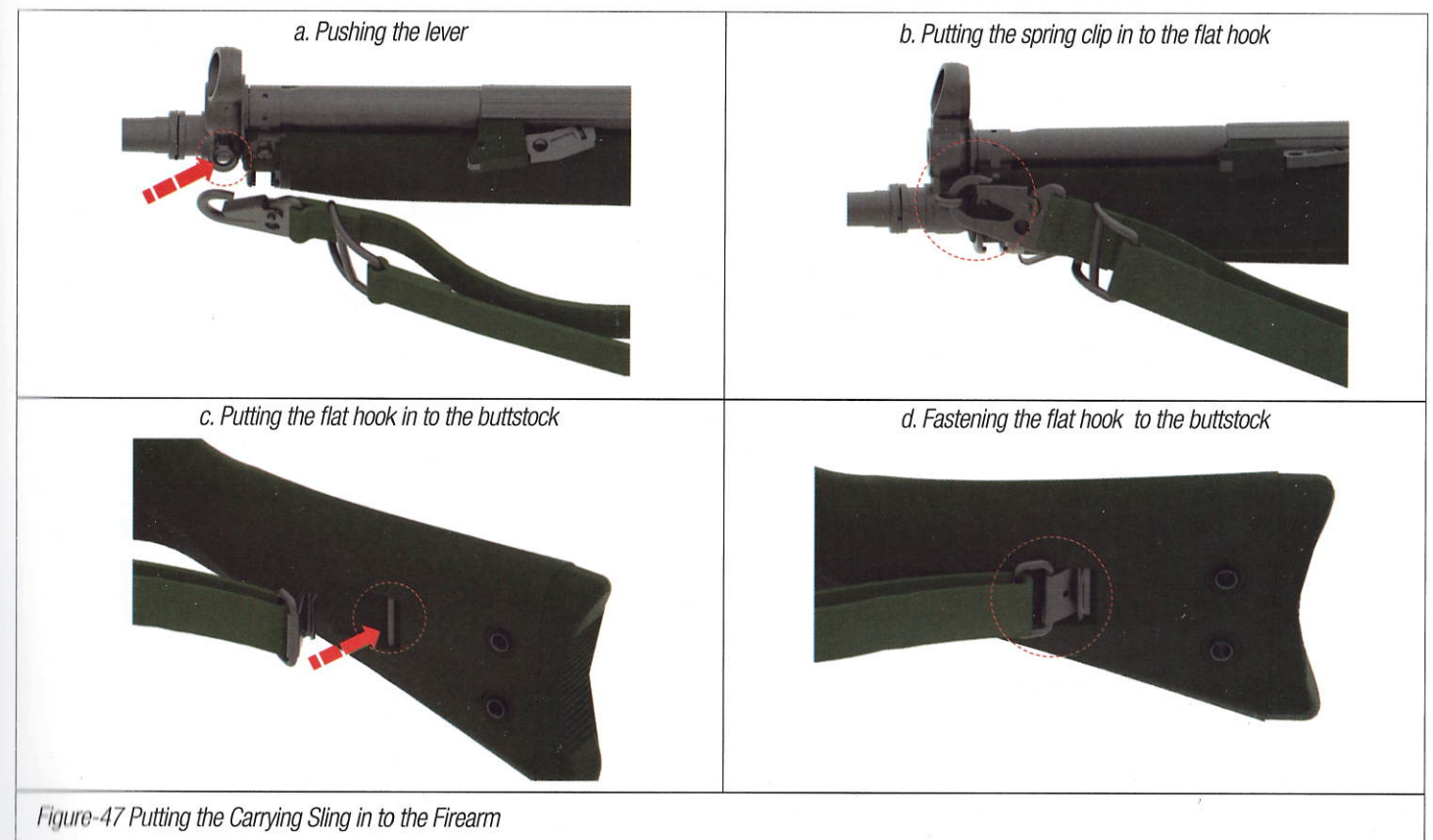

By pushing the lever on the spring clip, put the spring clip in to the eye on the front sight holder (see image a and b). Put the flat hook in to the buttstock and fasten (see image a and b).

How to Wear The Multi-Purpose Carrying Sling

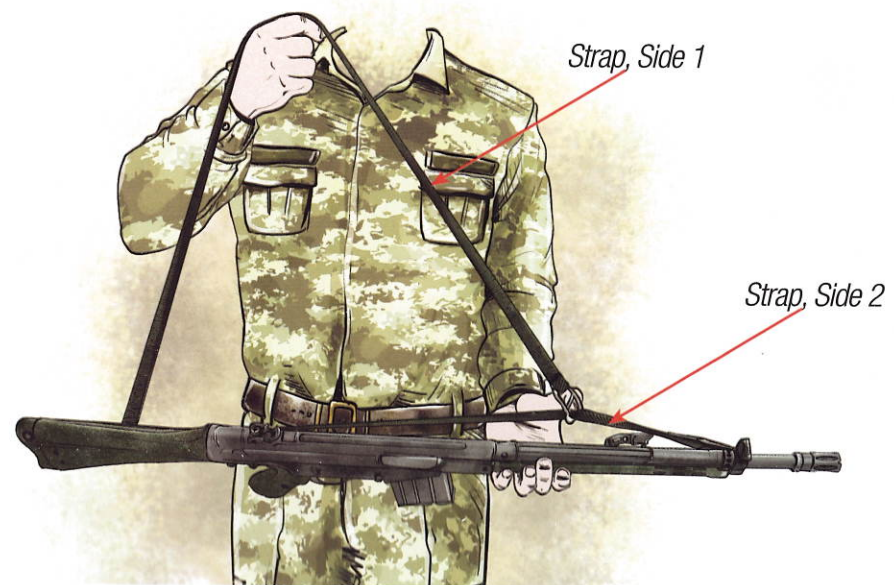

Figure-48 How to Wear The Multi-Purpose Carrying Sling

Carrying and Slings Modes

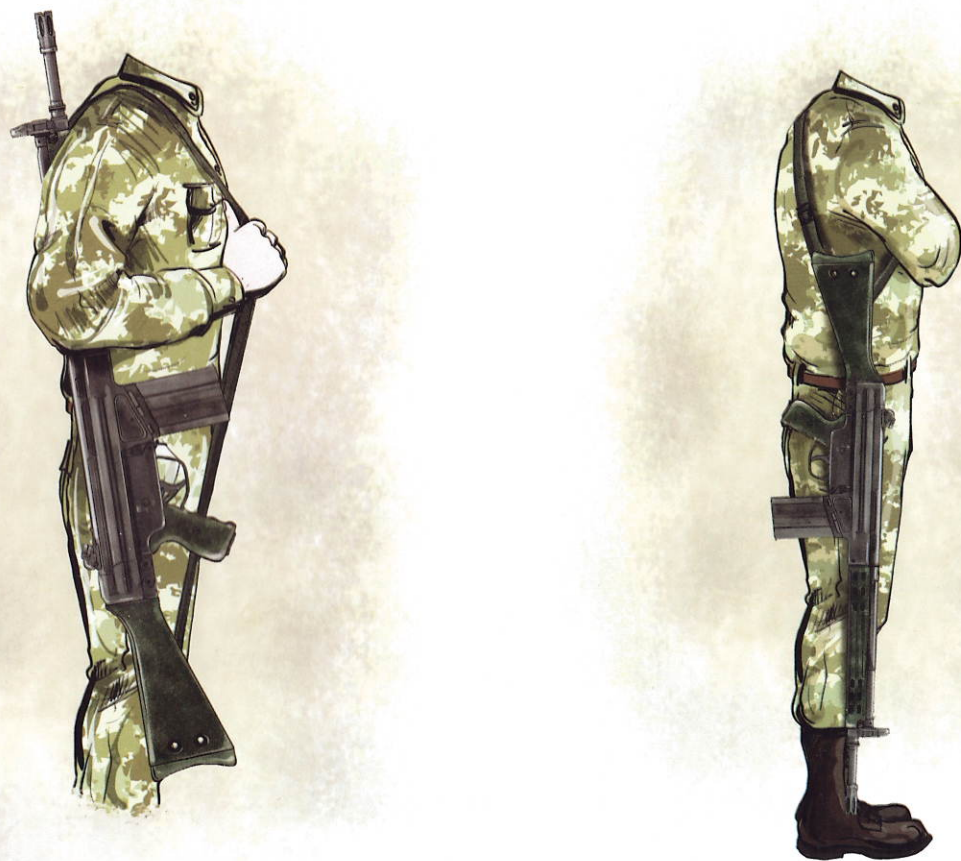

Figure-49 Carrying and Slings Modes

Shooting Modes



Figure-49 Carrying and Slings Modes

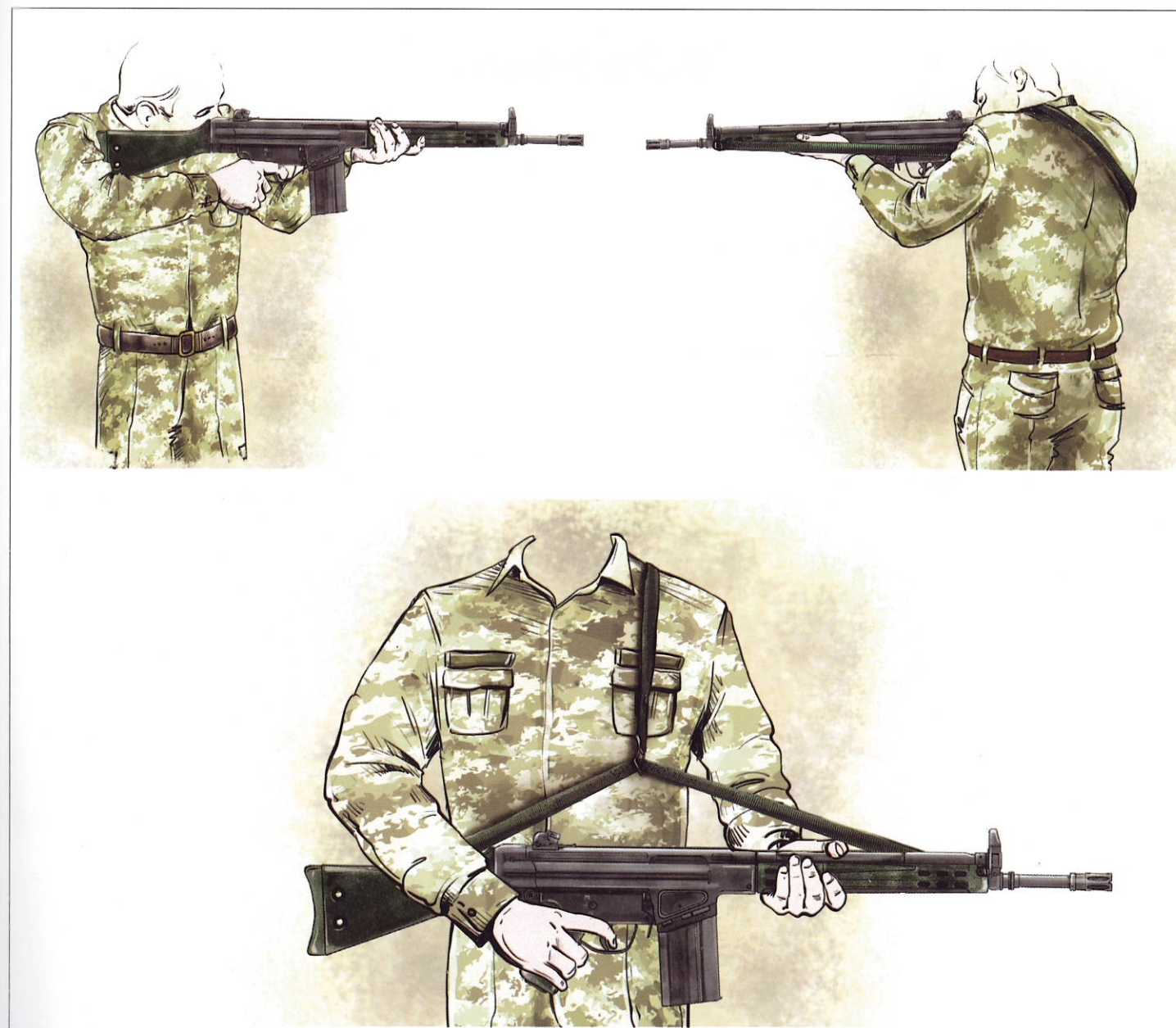

Figure-50 Shooting Modes



TROUBLESHOOTING

NO.	ISSUE	PROBABLE CAUSE	CORRECTIVE ACTION
1	Failure to fire	Firing pin broken Firing pin tip worn Firing pin spring broken Faulty ammunition Bolt carrier not in battery Damage/obstruction in trigger pack	Replace firing pin Replace firing pin Replace firing pin spring Replace ammunition Recharge firearm Repair trigger pack
2	Failure to extract	Extractor broken Extractor spring broken Bolt face has obstruction	Replace extractor Replace extractor spring Clean bolt face
3	Failure to eject	Ejector broken	Replace ejector
4	Failure to feed	Magazine not fully seated Magazine catch not engaged Magazine lips deformed Obstruction of charging handle movement Faulty ammunition	Fully insert magazine until it locks Inspect magazine latch button and paddle Replace magazine Ensure charging handle moves freely Replace ammunition.
5	Failure to chamber	Bolt face has obstruction Obstruction in trunnion/chamber Faulty ammunition Weak recoil spring	Clean bolt face Clean trunnion/chamber Replace ammunition Replace recoil spring
6	Failure to go into battery	Obstruction in trunnion/chamber Faulty ammunition Damaged bolt assembly Bolt face has obstruction Weak recoil spring	Clean trunnion/chamber Replace ammunition Repair bolt assembly Clean bolt face Replace recoil spring



CAUTION: IF ABOVE CORRECTIVE ACTIONS DO NOT REMEDY ISSUE, PLEASE SEEK ASSISTANCE FROM QUALIFIED GUNSMITH OR ARMORER BEFORE CONTACTING MECHANICAL AND CHEMICAL INDUSTRIES CORPORATION.

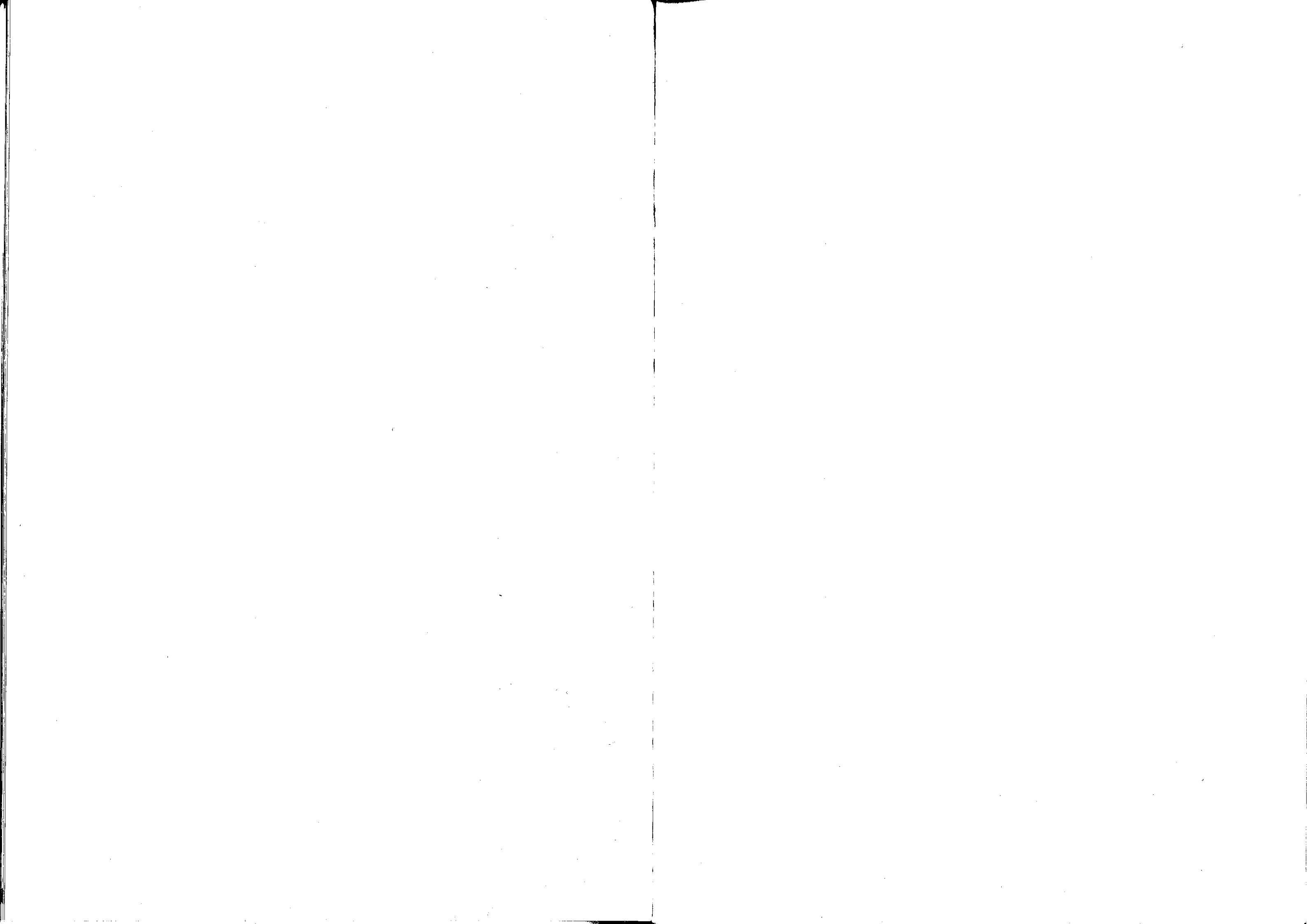

G3 AUTOMATIC RIFLE

RELIABILITY BY DESIGN MKE

7.62x51mm G3 AUTOMATIC



G3 AUTOMATIC 7.62x51mm

Mechanical and Chemical Industries Corporation

7.62x51mm G3 AUTOMATIC

Mechanical and Chemical Industries Corporation

Tandoğan 06330 ANKARA /TURKEY • T: +90 312 296 10 00 • F: +90 312 213 13 62
mkek@mkek.gov.tr • www.mkek.gov.tr

G3 AUTOMATIC RIFLE

7.62x51 mm

USER MANUAL
V.01